

Marathon Sensors Inc.
Multipro Operators Manual



***Marathon
Sensors Inc.***

COPYRIGHT © 2000

MARATHON SENSORS INC.

MARATHON SENSORS INC.

This manual has part number F200034

Copyright ©1998 Marathon Sensors Inc.
3100 East Kemper Road, Cincinnati, Ohio 45241
Telephones (513)772-1000 1-800-547-1055 FAX:(513) 326-7090
On the NET - marathonsensors.com

No part of this document may be stored or reproduced by any means whatsoever without prior written permission from Marathon Sensors Inc.

Multipro and Carbpro are trademarked to Marathon Sensors. Process Master or PM6 are trademarks of Atmosphere Furnace Company. All other trademarks are duly noted and are the sole properties of their owners. No attempt at trademark or copyright infringement is intended or implied.

The Multipro is a two channel process controller that is meant to be used by the industrial operator at his or her own risk. Marathon makes no warranties express or implied beyond the written warranty presented at initial purchase. Marathon is not responsible for any product, process damage, or injury resulting from the use of this product and makes no warranties with respect to the contents hereof and specifically disclaims any warranties of merchantability or fitness for any particular application or purpose.

Revision Date: April 24, 2001

Revision number 2.15

MARATHON SENSORS INC.

Table of contents:

Installation Safety Requirements	3
Installation requirements for EMC	5
Technical Specification.....	6
Multipro Features	10
INSTALLATION	12
THERMOCOUPLES AND OTHER SIGNAL WIRES.....	15
CHART RECORDERS	15
ALARMS	15
ELECTRICAL CONNECTIONS	16
COMMUNICATIONS	18
ANALOG	19
ANALOG OUTPUT.....	19
OUTPUT CONTACT SELECTION.....	20
MULTIPRO FRONT PANEL	21
ACCESSORY JACK.....	23
MULTIPRO FULL MENU PAGE	24
CONFIGURATION AND MENU SCREENS	26
MULTIPRO ACTIVE ALARMS PAGE.....	27
MULTIPRO ALARM DISPLAY PAGE.....	28
MULTIPRO ALARM MENU	29
MULTIPRO ANALOG EVENTS SETUP MENU.....	30
ANALOG EVENTS OFFSET SPAN	31
MULTIPRO ANALOG OUT MENU.....	32
MULTIPRO AUX COMMUNICATIONS MENU	33
MULTIPRO BASIC STATUS PAGE	35
MULTIPRO CALCULATIONS SETUP MENU	36
MULTIPRO CALIBRATION MENU.....	37
MULTIPRO CONTROL SETUP MENU.....	38
MULTIPRO DATA PAGE.....	39
MULTIPRO DIGITAL EVENTS SETUP MENU	40
MULTIPRO DIGITAL EVENTS PAGE.....	41
MULTIPRO EXTERNAL ANALOG DATA PAGE	42
MULTIPRO FILTER SETUP PAGE	43
MULTIPRO FRONT PANEL PAGE.....	44
MULTIPRO GENERIC DISPLAY PAGE.....	45
MULTIPRO HOST COMMUNICATIONS MENU.....	46
INPUT SETUP	47
INPUT ADJUSTMENT.....	48
MULTIPRO LCD TEST.....	49
MULTIPRO LOCK/SERVICE PAGE	50
MULTIPRO LOGIC PROGRAM PAGE.....	51
MULTIPRO LOGIC EDIT SCREEN.....	52
MULTIPRO LOGICAL EVENTS PAGE	53
MULTIPRO LOOPS PAGE	54

MARATHON SENSORS INC.

MULTIPRO MASTER TIMER PAGE	56
MULTIPRO OPERATOR INPUTS PAGE	57
MULTIPRO PASSWORD ENTRY	58
MULTIPRO PROBE CARE DISPLAY	60
MULTIPRO PROBE MAINTENANCE MENU	61
MULTIPRO PROBE VERIFICATION PAGE	63
MULTIPRO PROGRAMMER MENU	64
VERSION 3.5 RECIPE PROGRAMMING COMMANDS	65
MULTIPRO PROGRAMS PAGE.....	67
MULTIPRO PULSE SETUP PAGE.....	68
MULTIPRO RECIPE MENU	69
MULTIPRO RECIPE EDIT PAGE	70
MULTIPRO REDOX METALS PAGE	71
MULTIPRO REMAINING TIME PAGE.....	72
MULTIPRO SET CLOCK PAGE	73
MULTIPRO SET DEFAULT PAGE.....	74
MULTIPRO SETPOINTS PAGE.....	75
MULTIPRO SLAVE PAGE.....	76
MULTIPRO SLAVE STATUS PAGE	77
MULTIPRO SOFT ALARM DIR PAGE	79
MULTIPRO SPEC # ENTRY PAGE.....	80
SPEC # SELECT	81
MULTIPRO TEXT DISPLAY PAGE	83
MULTIPRO TEXT ENTRY PAGE	84
MULTIPRO TIMERS DISPLAY PAGE.....	85
MULTIPRO TREND 1 - 8 DISPLAY	86
MULTIPRO TREND SETUPS PAGE	87
MULTIPRO TREND 1 - 8 ZOOM.....	89
MAINTENANCE AND TROUBLESHOOTING	92
FUSE	93
PASSWORD PROTECTION	94
TECHNICAL BACKGROUND.....	95
UNDERSTANDING THE ELLINGHAM DIAGRAM.....	98
CALIBRATION	107
4 – 20 MILIAMP DC INPUT DAUGHTER BOARD CALIBRATION	113
RTD DC INPUT DAUGHTER BOARD CALIBRATION	114
O2 FOR OXYGEN INPUT DAUGHTER BOARD CALIBRATION	115
ANALOG OUTPUT CALIBRATION	116
SPARE PARTS LIST	119
TABLE OF ABBREVIATIONS	120
Glossary:.....	122

MARATHON SENSORS INC.

Installation Safety Requirements

Safety Symbols

Various symbols are used on the instrument, they have the following meaning:



The functional earth connection is required for safety purposes and to ground RFI filters.

Personnel

Installation must only be carried out by qualified personnel.

Enclosure of live parts

To prevent hands or metal tools touching parts that may be electrically live, the controller must be installed in an enclosure.

Caution: Live sensors

Do not connect live sensors to any signal input of the Multipro. Live sensors are sensors that must be connected to the main's supply. The Multipro has transient protection circuits connect between the inputs and the earth connection which could be damaged by live sensors.

Wiring

It is important to connect the controller in accordance with the wiring data given in this handbook. Take particular care not to connect AC supplies to the low voltage sensor input or other low level inputs and outputs. Only use copper conductors for connections (except thermocouple inputs) and ensure that the wiring of installations comply with all local wiring regulations. For example in the in the UK use the latest version of the IEE wiring regulations, (BS7671). In the USA use NEC Class 1 wiring methods.

Power Isolation

The installation must include a power isolating switch or circuit breaker. This device should be in close proximity to the controller, within easy reach of the operator and marked as the disconnecting device for the instrument.

Earth leakage current

Due to RFI Filtering there is an earth leakage current of less than 0.5mA. This may affect the design of an installation of multiple controllers protected by Residual Current Device, (RCD) or Ground Fault Detector, (GFD) type circuit breakers.

MARATHON SENSORS INC.

Overcurrent protection

To protect the internal PCB tracking within the controller against excess currents, the AC power supply to the controller and power outputs must be wired through a fuse or circuit breaker specified in the technical specification.

Voltage rating

The maximum continuous voltage applied between any of the following terminals must not exceed 264Vac:

- line or neutral to any other connection;
- relay or triac output to logic, dc or sensor connections;
- any connection to ground.

The controller should not be wired to a three phase supply with an unearthed star connection. Under fault conditions such a supply could rise above 264Vac with respect to ground and the product would not be safe.

Voltage transients across the power supply connections, and between the power supply and ground, must not exceed 2.5kV. Where occasional voltage transients over 2.5kV are expected or measured, the power installation to both the instrument supply and load circuits should include a transient limiting device.

These units will typically include gas discharge tubes and metal oxide varistors that limit and control voltage transients on the supply line due to lightning strikes or inductive load switching. Devices are available in a range of energy ratings and should be selected to suit conditions at the installation.

Conductive pollution

Electrically conductive pollution must be excluded from the cabinet in which the controller is mounted. For example, carbon dust is a form of electrically conductive pollution. To secure a suitable atmosphere in conditions of conductive pollution, fit an air filter to the air intake of the cabinet. Where condensation is likely, for example at low temperatures, include a thermostatically controlled heater in the cabinet.

Over-temperature protection

When designing any control system it is essential to consider what will happen if any part of the system should fail. In temperature control applications the primary danger is that the heating will remain constantly on. Apart from spoiling the product, this could damage any process machinery being controlled, or even cause a fire.

Reasons why the heating might remain constantly on include:

- the temperature sensor becoming detached from the process;
- thermocouple wiring becoming a short circuit;
- the controller failing with its heating output constantly on;
- an external valve or contactor sticking in the heating condition;
- the controller setpoint set too high.

Where damage or injury is possible, we recommend fitting a separate over-temperature protection unit, with an independent temperature sensor, which will isolate the heating circuit.

Please note that the alarm relays within the controller will not give protection under all failure conditions.

MARATHON SENSORS INC.

Grounding of the temperature sensor shield

In some installations it is common practice to replace the temperature sensor while the controller is still powered up. Under these conditions, as additional protection against electric shock, we recommend that the shield of the temperature sensor is grounded. Do not rely on grounding through the framework of the machine.

Installation requirements for EMC

To ensure compliance with the European EMC directive certain installation precautions are necessary as follows:

- When using relay or triac outputs it may be necessary to fit a filter suitable for suppressing the emissions. The filter requirements will depend on the type of load. For typical applications we recommend Schaffner FN321 or FN612.

Routing of wires

To minimise the pick-up of electrical noise, the wiring for low voltage dc and particularly the sensor input should be routed away from high-current power cables. Where it is impractical to do this, use shielded cables with the shield grounded at one end.

MARATHON SENSORS INC.

Technical Specification

Environmental ratings

Operating temperature:	0 to 55°C. Ensure the enclosure provides adequate ventilation.
Relative humidity:	5 to 85%, non-condensing.
Atmosphere:	The instrument is not suitable for use above 2000m or in explosive or corrosive atmospheres.

Equipment ratings

Supply voltage:	120Vac -15%, +10%, or optionally: 240Vac -15%, +10%
Supply frequency:	48 to 62Hz.
Power consumption:	15 Watts maximum.
Relay Outputs (isolated):	Maximum: 264Vac, 1A resistive. Minimum: 12Vdc, 100mA.
Triac outputs (isolated):	30 to 264Vac. Maximum current: 1A resistive.
Leakage current:	The leakage current through triac and relay contact suppression components is less than 2mA at 264Vac, 50Hz.
Over current protection:	External over current protection devices are required that match the wiring of the installation. A minimum of 0.5mm ² or 16awg wire is recommended. Use independent fuses for the instrument supply and each relay or triac output. Suitable fuses are T type, (EN 60127 time-lag type) as follows; Instrument supply: 85 to 264Vac, 1A, (T). Relay outputs: 1A (T). Triac outputs: 1A (T).
Low level i/o:	All input and output connections other than triac and relay are intended for low level signals less than 24V.
DC output (Isolated):	0 to 20mA (600Ω max), 0 to 10V (500Ω min).

MARATHON SENSORS INC.

General

Programs

200 - 19 step recipe programs

200 - 24 step logic programs

Alarm output: 2 user selectable outputs for process alarms.

Analog output: adjustable Voltage (0 to 5 V dc) or milliamperage (0 to 22ma) based on various selectable sources.

Auxiliary and Slide

Wire input

impedance: 44 M ohm

Auxiliary and

Slidewire

input range: -50 to 2000 millivolts DC

Control Outputs: 2 configurable outputs allowing dual control on both loops for ON / OFF, Time-proportioning or position-proportioning control. Also can use events - see table. 1 amp rating.

Serial interface:

Host: RS-422 1200/4800/ 9600 / 19200 / 38400 / 76800
BAUD Full / Half duplex, Even /no parity, MMI or Modbus protocol

Auxiliary: RS-422 1200 /4800 / 9600 / 19200 / 38400 / 76800
BAUD, Full/Half duplex, Even No/ Parity, 1 stop bit, Multiple modes.

OPTOMUX: RS-422 1200 / 4800 BAUD, 8 Bit, no parity, 1 stop
Bit Full Duplex, 2 pass OPTOMUX protocol.

**BASIC terminal
Port:** RS-422 4800 BAUD, Full duplex, for BASIC
interpreter access. May be used as second host port.

Dimensions: 5.75" height, 5.75" width, 10.5" length

Event Output / 4 events configured for in or out.

Input: 3 inputs as defined by daughter boards

Panel cut out: 5.43" X 5.43" square

MARATHON SENSORS INC.

PID Constants:

Proportional Band 1 to 9999
Reset 0 to 99.99 RPM
Rate 0 to 9.99 minutes
Cycle Time 0 to 250 seconds
Load Line -100 to 100 %
High limit 0 to 100 %
Low limit -100 to 100 %

Setpoints:

-999 to 9999

Signal display

range:

- 300 to 3500 (+ 4) Depending upon thermocouple type. - 999 to 9999 for programmed values

Thermocouple Board

Signal input range:

-10 to + 64 mV

Accuracy:

± .15% FS plus ± 1 digit of the display

Resolution:

8uV over input range

Thermocouple:

B: Platinum 30% Rhodium vs. Platinum 6% Rhodium

C: Tungsten 5% Rhenium vs. Tungsten 26% Rhenium

E: Chromel-Constantan

J: Iron-Constantan

K: Chromel-Alumel

N: Nickel 14.2% Chromium 1.4% Silicon vs. Nickel 4.4%

Silicon 0.1% Magnesium

NNM: Nickel vs. Nickel 18% Molybdenum

R: Platinum vs Platinum 13% Rhodium

S: Platinum vs Platinum 10% Rhodium

T: Copper-Constantan

Auxiliary mV Board

Signal input range:

0 to 2000 mV

Accuracy:

± .15% FS plus ± 1 digit of the display

Resolution:

244uV over input range

Carbon Potential

Accuracy:

.02% with a 2% FS Carbon

Weight:

Approximately 11 pounds

MARATHON SENSORS INC.

Electrical safety

Standards:	EN 61010, Installation category II, pollution degree 2. CSA C22.2 No.142-M1987.
Installation category II:	Voltage transients on any mains power connected to the instrument must not exceed 2.5kV.
Pollution degree 2:	Conductive pollution must be excluded from the cabinet in which the instrument is mounted.
Isolation:	The event inputs and event, control and alarm outputs have reinforced insulation to provide protection against electric shock.

MARATHON SENSORS INC.

Multipro Features

LCD graphics display can display standard size and double size characters.

Allows information displays showing process values, control modes, output %, program time, recipe program number and step on one display.

Shows up to 8 configurable graphic Trend Displays.

Can display text based Alarm Messages.

Displays easy to use Menu Structures

Selection Knob

Allows for quick selection and scan of menu items. Provides a rate sensitive numeric input. The faster the knob is turned, the quicker the number changes.

The knob incorporates an internal push-button. A single press is the same as pressing the ENTER key. Two quick presses is the same as pressing the ESC key.

Simplified Key Selection

Only three keys are provided; ENTER, GOTO, and ESC. ENTER accepts a selection or value. GOTO will display the GOTO Menu. ESC is used to cancel a selection or go back to a previous page.

Accessory Jack

The front panel jack is used to connect a bar code reader, mouse, glidepoint pad, or computer.

MARATHON SENSORS INC.

INSTALLATION

INSTALLATION PREPARATIONS

The Multipro instrument is designed for .125" thick panel mounting in a half DIN standard opening of 5.43" square (adapter panels available by special order). Required rear clearance is 10.5" to allow for wiring.

As with all solid state equipment, the controller should be away from excessive heat, humidity, and vibration. Since the unit uses a LCD display, it should be mounted so that direct sunlight will not interfere with the display's visibility. The instrument requires 100/120/200/240 volts ac (jumper selectable on power interconnect board inside the REAR PANEL) 50/60 Hz and should not be on the same circuit with other noise-producing equipment such as induction machines, large electrical motors, etc. All instrument wiring must be run separate from all control wiring. Noise suppression must be employed (noise - a unwanted electrical signal or disturbance). Commercial noise suppression equipment is available. MMI can provide recommended parts or numbers for transient noise suppression from solenoid valves or similar equipment.

MARATHON SENSORS INC.

PANEL MOUNTING/REMOVAL

Because the instrument uses a ventilated enclosure, it is not dust-tight. It should always be mounted in a Nema 12 type 1 control panel.

To mount the instrument in a control panel, cut a 5.43" square hole in the necessary location on the panel. The following procedure should be followed to mount the Multipro in the panel:

1. INSERT the unit into 5.43" square cut out in the panel.
2. While supporting the unit, insert one, slotted, clamping bracket into the small rectangular cutout on the side of the unit

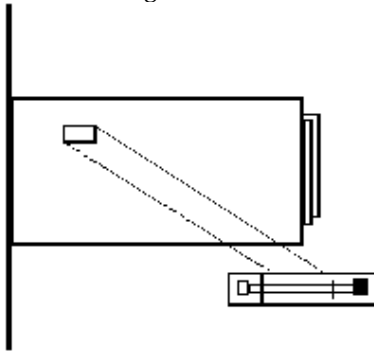

3. Repeat step 2 for the opposite side of the unit.
4. With a 7/16" socket or wrench, alternately tighten bolts on either side of the instrument until the springs are compressed halfway to ensure a rigid mounting.

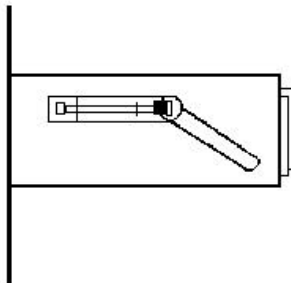

[To prevent damage or warping of the unit's case, do not over tighten the clamp bolts.]

MARATHON SENSORS INC.

To remove the unit, loosen the side clamping brackets and reverse steps 1 through 3 above. On subsequent removals and installations the rear panel can be removed (4 screws) and the wiring does not have to be disturbed.

***** **Warning** *****

All connections, rear panel installations and removals; as well as triac board installations and removals must be done with power removed from terminal block A (TBA) and terminal block B (TBB). All other (PC) boards should only be removed or installed with power off via the toggle switch mounted on the triac board. Otherwise, serious personal and/or equipment damage can occur.

MARATHON SENSORS INC.

THERMOCOUPLES AND OTHER SIGNAL WIRES

The wiring used to connect the signal wires to the instrument should be run in conduit, separate from any AC lines in the area. This provides noise immunity and physical protection. Thermocouples should be wired with the appropriate alloy extension wire with no termination other than at the instrument. As with all cold-junction compensating instruments, EXTREME CARE should be used when an existing thermocouple is to be used for both the Controller and another instrument at the same time.

CHART RECORDERS

If a chart recorder is to be used, it must have input specifications within 0 to 5 V dc, or 4 to 20 mA. The ideal location of the recorder is adjacent to the instrument but it may be located remotely if the connecting wires are properly shielded. Long wiring runs from the chart recorder outputs may require resistive termination (2 K ohms or so) at the remote end to decrease the effects of electrical noise. For best results, the chart recorder input(s) should be isolated from ground. Another possible configuration is to calibrate the Analog output to 0-20 mA and use a terminating resistor to get the required voltage at the chart recorder. This setup will help reduce noise at the chart recorder.

ALARMS

Two user-programmable alarm contacts are available for connection at the Multipro rear panel. The system design for alarm usage will determine the alarm wiring and configuration.

MARATHON SENSORS INC.

ELECTRICAL CONNECTIONS

Connections to the unit are made via four terminal blocks, located on the REAR PANEL, labeled TBA, TBB, TBC, and TBD. Positions are numbered from top to bottom. AC power, event, control, and alarm connections are made on TBA and TBB. All communications are located on TBC and all analog I/O signals are located on TBD. Refer to your installation drawings for a complete layout of the electrical connections.

Note: 'TBA' refers to terminal block 'A'.
'N.O.' refers to Normally open contact.
'VAC' refers to Volts AC

AC POWER

The Multipro requires 100/120/200/240 Vac at 1/4 AMP.

VAC	TBA-1,TBA-2
COMMON	TBB-1,TBB-2
EARTH GROUND	TBA-3,TBB-3

CONTROL CONTACTS

Eight control contacts are located on TBA and TBB.

EVENT POWER	TBA-4
EVENT NEUTRAL	TBB-4
EVENT #0	TBA-5
EVENT #1	TBB-5
EVENT #2	TBA-6
EVENT #3	TBB-6
CONTROL #1 N.O.	TBB-7
COM	TBA-7
CONTROL #2 N.O.	TBB-8
COM	TBA-8
ALARM #1 N.O.	TBB-9
COM	TBA-9
ALARM #2 N.O.	TBB-10
COM	TBA-10

MARATHON SENSORS INC.

Terminal layout:

TB-A

1 - LINE
2 - LINE
3 - GROUND
4 - EVENT POWER
5 - EVENT #0
6 - EVENT #2
7 - CONTROL #1 - COM
8 - CONTROL #2 - COM
9 - ALARM #1 - COM
10 - ALARM #2 - COM

TB-B

1 - NEUTRAL
2 - NEUTRAL
3 - GROUND
4 - EVENT NEUTRAL
5 - EVENT #1
6 - EVENT #3
7 - CONTROL #1 N.O.
8 - CONTROL #2 - COM
9 - ALARM #1 N.O.
10 - ALARM #2 N.O.

TB-C

1 - RX+
2 - RTX - HOST
3 - TX+
4 - TX-

5 - RTX +
6 - RTX - AUX
7 - TX +
8 - TX -

9 - RTX +
10 - TRX - EVTS
11 - TX +
12 - TX -

13 - RTX +
14 - RTX - BASIC
15 - TX+
16 - TX +

17
18

TB-D

1 - INPUT #1+
2 - INPUT #1 -
3 - INPUT #1 V
4 - INPUT #2+

5 - INPUT #2 -
6 - INPUT #2 V
7 - INPUT #3 +
8 - INPUT #3 -

9 - INPUT #3 V
10
11
12

13 - ANALOG +
14 - OUT #1
15 - ANALOG +
16 - OUT #2

17
18

MARATHON SENSORS INC.

COMMUNICATIONS

Four communication busses are located at TBC and use RS-422 full or half duplex protocol for all ports. Typically, the HOST port will connect to a host computer; the AUXILIARY BUSS to other instruments (including those in the PRO series); the EVENTS PORT to OPTOMUX I/O devices; and the BASIC TERMINAL PORT to a remote terminal or other programmable devices.

HOST PORT:

RTX+ - TBC-1

RTX- - TBC-2

TX+ - TBC-3

TX- - TBC-4

AUX BUSS:

RTX+ - TBC-5

RTX- - TBC-6

TX+ - TBC-7

TX- - TBC-8

OPTOMUX PORT:

RTX+ - TBC-9

RTX- - TBC-10

TX+ - TBC-11

TX- - TBC-12

BASIC TERMINAL PORT:

RTX+ - TBC-13

RTX- - TBC-14

TX+ - TBC-15

TX- - TBC-16

MARATHON SENSORS INC.

ANALOG

The Multipro allows for three analog inputs with their individual functions determined by "daughter boards" located on the analog input board inside the unit. The standard connection, located at TBD, will allow for a thermocouple on inputs 1 and 3 and a millivolt measurements on input 2. All other inputs can be configured for voltage, milliamp, rtd, thermocouple inputs.

INPUT #1 + - TBD-1
 - - TBD-2 PROBE THERMOCOUPLE
 V - TBD-3
INPUT #2 + - TBD-4
 - - TBD-5 PROBE MILLIVOLTS
 V - TBD-6
INPUT #3 + - TBD-7
 - - TBD-8 THERMOCOUPLE
 V - TBD-9

ANALOG OUTPUT

Two independent and isolated analog outputs are provided on TBD and can be adjusted to any upper and lower limit within the ranges given: 0 to 5 Vdc or 0 to 22 mA to include the standard settings of 4 to 20 mA or 0 Vdc output. The change from V dc to mA is made through a DIP switch setting on the analog output board. Adjustments are made via on board potentiometers. See Maintenance and Troubleshooting for details of settings.

OUTPUT #1 + - TBD-13
 - - TBD-14
OUTPUT #2 + - TBD-15
 - - TBD-16

MARATHON SENSORS INC.

OUTPUT CONTACT SELECTION

To allow for full dual loop control, with two control contacts available for each loop, an "as needed" scheme is used. This calls for event contacts 2 and 3 to be attached as third and fourth control contacts when the setup requires it. If they are not needed they remain as events. If the events used selection is NO, then the event contacts 2 and 3 always remain as events.

Output Contact Configuration

Output Contact Configuration		LOOP 1			
LOOP 2	CONTROL OUTPUT	TP OF	TC OC	TD OD	MS PP
TP OF	LP1 FWD	OUT 1	OUT 1	OUT 1	OUT 1
	LP1 REV	-----	EVT 3	OUT 2	OUT 2
	LP2 FWD	OUT 2	OUT 2	EVT 3	EVT 3
	LP2 REV	-----	-----	-----	-----
TC OC	LP1 FWD	OUT 1	OUT 1	OUT 1	OUT 1
	LP1 REV	-----	EVT 3	OUT 2	OUT 2
	LP2 FWD	OUT 2	OUT 2	EVT 3	EVT 3
	LP2 REV	EVT 3	EVT 2	EVT 2	EVT 2
TD OD	LP1 FWD	OUT 1	OUT 1	OUT 1	OUT 1
	LP1 REV	-----	EVT 3	OUT 2	OUT 2
	LP2 FWD	OUT 2	OUT 2	EVT 3	EVT 3
	LP2 REV	EVT 3	EVT 2	EVT 2	EVT 2
MM NOTE 1	LP1 FWD	OUT 1	OUT 1	OUT 1	OUT 1
	LP1 REV	-----	OUT 2	OUT 2	OUT 2
	LP2 FWD	NOTE 2	EVT 3	-----	-----
	LP2 REV	OUT 2	NOTE 3	-----	-----
PP	LP1 FWD	OUT 1	OUT 1	OUT 1	OUT 1
	LP1 REV	-----	EVT 3	OUT 2	OUT 2
	LP2 FWD	OUT 2	OUT 2	EVT 3	EVT 3
	LP2 REV	EVT 3	EVT 2	EVT 2	EVT 2

Note:

TP = Time Proportion

TC = Time Proportion with compliment.

TD = Time Proportion dual mode.

OF = on/off control.

OC = On/Off with compliment.

OD = On/Off dual mode.

MS = Motor with Slidewire

PP = Position Proportioning.

MM = Multimode.

MARATHON SENSORS INC.

- NOTE 1 MM (Multi Mode) for loop 2 is a dual mode (-100% to + 100%) when loop 1 is in TP, OF, or OC. Otherwise it is a single mode (0- + 100%)
- NOTE 2 Analog output 1, if set to PO2, will be zero to full scale for 0 to - 100% if loop 2 is MM and loop 1 is in TP, OF, TC, or OC.
- NOTE 3 Analog output 2, if set to PO2, will be zero to full scale for 0 to - 100% if loop 2 is in MM and loop 1 is in TP, OF, TC, or OC.
- NOTE 4 Only one analog output needs to be set to PO2 for notes 2 and 3 to apply.

MULTIPRO FRONT PANEL

The Multipro front panel consists of an LCD graphics display, three keys, a knob, and an accessory input jack.

LCD DISPLAY

The LCD display on the Multipro is 128 by 128 pixels. A normal character uses an 8 by 8 pixel space which means the display is 16 lines of 16 characters. The characters can be displayed in a condensed mode which allows 21 characters on a line. To enhance readability double size and quad size characters can be used. Double size characters are 16 by 16 pixels. Proportional spacing is used when printing so that a skinny letter like an 'i' uses less space than a fat one like an 'R'. Quad size characters use 32 by 32 pixels and are only available as numbers. Quad size characters also use proportional spacing.

The bottom line of the display is reserved for system messages. The last three characters on the left of this line will always display a unique page number. This number may consist of letters and numbers which identifies the page (screen). Three other items may appear on the bottom line. On the far left 'COM' may flash if the Multipro is transmitting on its host port. In the middle left 'KEY' will appear whenever one of the three keys is being pressed. The remaining space on the line (between 'KEY' and the page number) is used to display programmer alarms. The alarm is displayed by flashing 'PAL' followed by the alarm number.

MARATHON SENSORS INC.

KEYS

The three keys are labeled 'Enter', 'GoTo', and 'Esc'. The 'Enter' key is used to accept a selection or value. The 'GoTo' key is used to bring up first the 'Oper Menu' pressing 'GoTo' again will bring up the 'Full Menu' which allows direct selection of any page. When using the Recipe or Logic Editor, the 'GoTo' key brings up a function menu. The 'Esc' or escape key is used to cancel a selection or go back to the previous page. There are times when a key may seem to have no effect since the action would be inappropriate; however, the word 'KEY' will always show on the bottom line of the display. Pressing the 'ESC' and the 'GoTo' keys together will clear all previous pages and return to the default page.

KNOB

The knob is attached to a rotary encoder with a push-button switch. Menu selections and numeric inputs are made by rotating the knob. Rotating the knob clockwise moves the highlight bar up the menu or increases the numeric value. Rotating the knob counter clockwise moves the highlight bar down the menu or decreases the numeric value. The response of the knob depends on what is being changed. When moving the highlight bar, only the direction of the rotation is considered. This prevents the knob from being too sensitive. When changing a value, the speed of rotation determines the size of the change. The knob has 32 detents per revolution. Normally each detent changes the value by 1. If the knob is rotated slightly faster than normal, each detent would change the value by 10. Quicker rotations will cause changes of 100. Once the "feel" of the knob is acquired, numeric values can be set very quickly.

Pressing on the knob activates the internal push-button. There is a short delay before any action occurs to check for additional presses of the knob. A single press of the knob is the same as the 'Enter' key. A double press of the knob is the same as the 'Esc' key. When the default page is being displayed, a single press of the knob, 'GOTO' key, or the 'ENTER' key will select the OPER MENU page. When using the knob, be careful not to rotate the knob when pressing it. This could cause incorrect selections to be made.

MARATHON SENSORS INC.

ACCESSORY JACK

The accessory jack is used to connect either a bar code reader, a computer, or a computer mouse. The bar code reader can be used to enter part numbers or load numbers, which if setup or configured can start the correct recipe from an internal database. The computer mouse or glidepoint pad can be used in a similar manner as the knob.

Note: Connect computer with cable P810202 Multipro laptop cable.

MARATHON SENSORS INC.

MULTIPRO FULL MENU PAGE

FULL MENU

SELECT PAGE

* * * * *

PROCESS	001
ACTIVE ALARMS	002
ALARM DISPLAY	003
ALARM 1 SETUP	004
ALARM 2 SETUP	005
ANALOG EVENTS	006
ANALOG EVENTS O/S	007
ANALOG OUT	008
AUX COMMS	009
BASIC STATUS	010
CALCULATIONS	011
CALIBRATION	012
CONTROL SETUPS	013
DATA	014
DIGITAL EVENTS	015
DIG EVENTS	016
EXT ANALOG	017
FILTERING	018
FRONT PANEL	019
GENERIC DISPLAY	020
HOST COMMS	021
INPUT SETUP	022
INPUT ADJUST	023
LCD TEST	024
LOCK/SERVICE	025
LOGIC CONTROL	026
LOGIC EDIT	027
LOGICAL EVENTS	028
LOOPS	029
LOOP 1 TUNING	030
LOOP 2 TUNING	031
MASTER TIMER	032
OPERATOR INPUTS	033
OPERATOR MENU	034
PASSWORD ENTRY	035
PRESET MEMORY	036
PROBE CARE	037
PROBE MAINT	038

PROBE VERF	039
PROGRAMMER	040
PROGRAMS	041
PULSE SETUP	042
RECIPE CONTROL	043
RECIPE EDIT	044
REDOX METALS	045
REMAINING TIME	046
SET CLOCK	047
SET DEFAULT PAGE1	048
SETPOINTS	049
SLAVE	050
SLAVE STATUS	051
SLIDE SHOW	052
SLIDE SHOW SETUP	053
SOFT ALARM DIR	054
SPEC # ENTRY	055
SPEC # SELECT	056
TEXT DISPLAY	057
TEXT ENTRY	058
TIMERS	059
TREND1 DISPLAY	060
TREND2 DISPLAY	061
TREND3 DISPLAY	062
TREND4 DISPLAY	063
TREND5 DISPLAY	064
TREND6 DISPLAY	065
TREND7 DISPLAY	066
TREND8 DISPLAY	067
TREND SETUPS	068
TREND 1 ZOOM	069
TREND 2 ZOOM	070
TREND 3 ZOOM	071
TREND 4 ZOOM	072
TREND 5 ZOOM	073
TREND 6 ZOOM	074
TREND 7 ZOOM	075
TREND 8 ZOOM	076
VERSION	077
XXGRAPH	078
GOTO	079

MULTIPRO PROCESS PAGE

PROCESS	
MAN	3500
000	0
MAN	650 MV
000	0
LOAD #	
RECIPE #	0 STOPPED
TIME LEFT:	0 MINS

The PROCESS screen displays information on both control loops and the programmer. This screen is the default page unless another screen was selected under the DEFAULT PAGE SELECT screen.

MARATHON SENSORS INC.

CONFIGURATION AND MENU SCREENS

The Multipro operator menu can be reached by pressing 'GOTO' once. This allows access to the remaining time screen, setpoints used in auto mode, program condition, display and acknowledgement of alarms, and recipe selection through a part number list.

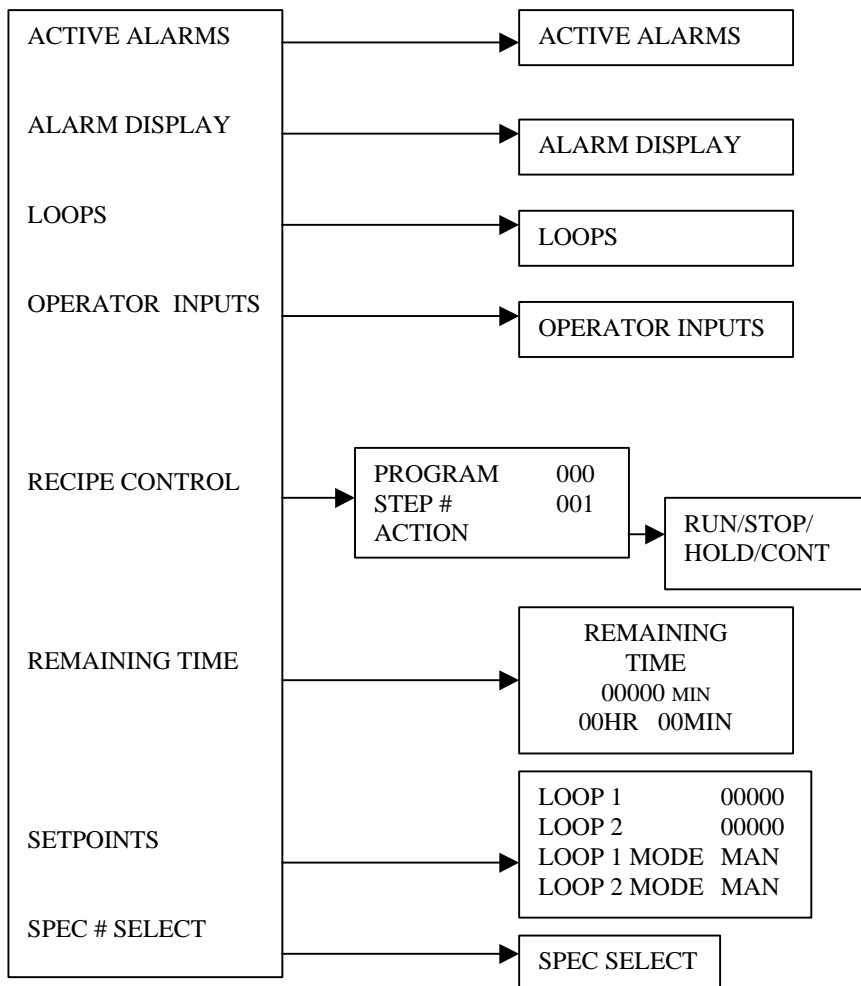

MARATHON SENSORS INC.

MULTIPRO ACTIVE ALARMS PAGE



ACTIVE ALARMS

This screen will display messages for any and all active alarm conditions. Use the knob to scroll through the messages if the screen is full. Active alarms will automatically clear from this screen when conditions change.

ALARM
DISPLAY

Press Enter to ACK
Esc to exit only.

This screen shows the current alarm that has not been acknowledged. Only the latest unacknowledged alarm will be displayed on this screen.

MARATHON SENSORS INC.

MULTIPRO ALARM MENU

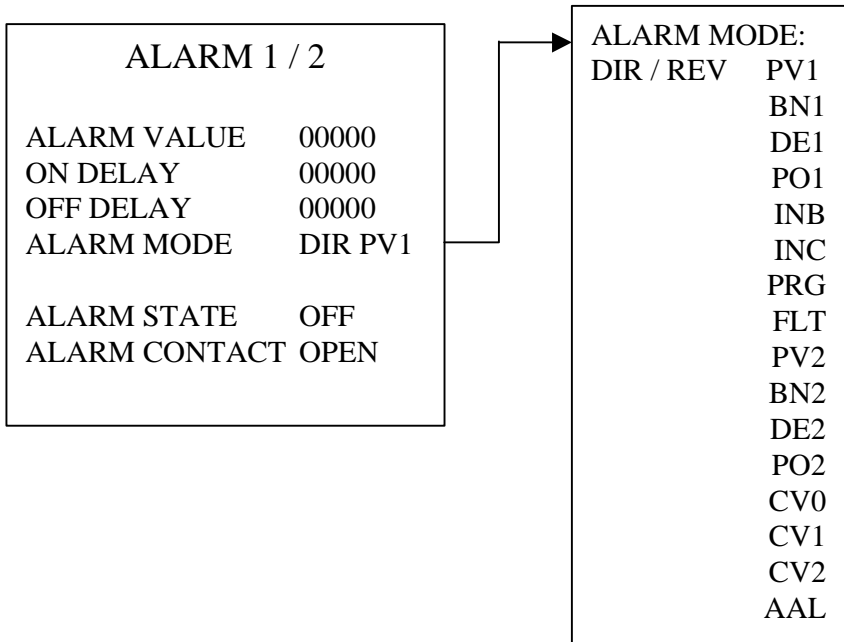

- PV - process variable, alarms above this value (Loop 1 or loop 2)
- BN - deviation band, +/- band around setpoint. Alarms outside of this band. (Loop 1 or loop 2)
- DE - deviation band, a band set above or below the setpoint. Alarms outside of this band. (Loop 1 or loop 2)
- PO - percent output, alarms above this value (Loop 1 or loop 2)
- CV - calculated values 0, 1, 2, 3. Alarms above this value
- INB - input B value
- INC - input C value
- PRG - program alarm (PAL)
- FLT - input fault
- AAL - Active Alarms; the alarm state will be ON if any alarm in the active alarm table defined by the logic program is ON.

Alarm state / alarm contact - display status of alarm condition and contact.
State can be on / off, contact can be close / open.

MARATHON SENSORS INC.

MULTIPRO ANALOG EVENTS SETUP MENU

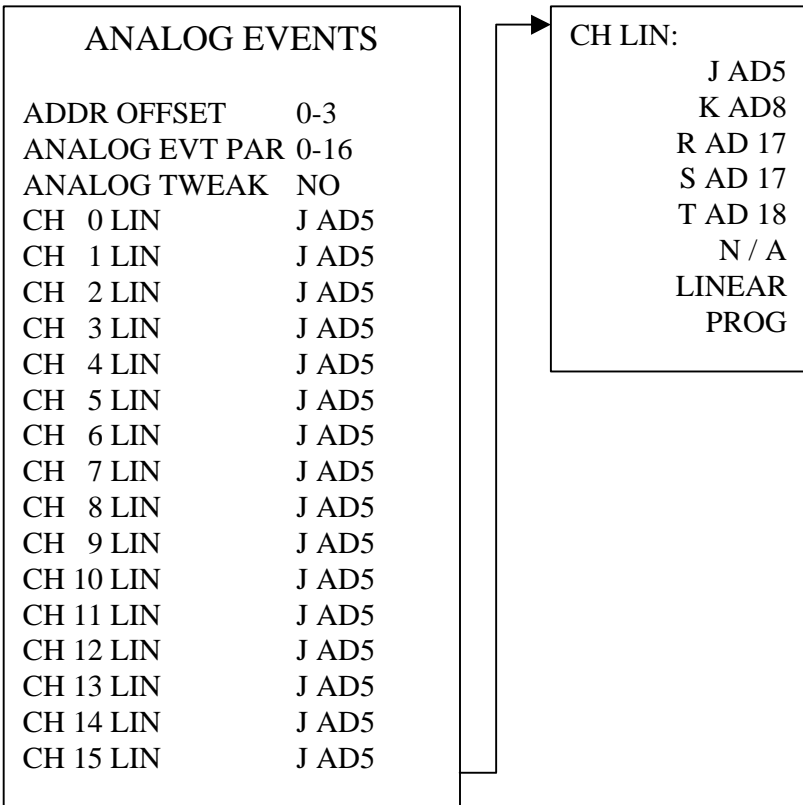

Up to 4 analog event boards can be added to the Multipro. Only one board at a time can be addressed through the addr offset parameter. Physical addresses for the analog opto boards starts at FC to FF. The addr offset parameter can be changed in a logic program to expand access to external analog input / output.

Analog events can be partitioned as inputs or outputs the same as digital events.

Analog tweak - yes, allows offset and span values for each channel. 0.0 offset and 1.000 span are defaults. (See analog events menu).

MARATHON SENSORS INC.

ANALOG EVENTS OFFSET SPAN

ANALOG EVTS OFFSET SPAN			
ANALOG TWEAK	NO/YES	ANALOG CH7	00000
ANALOG CH0	00000	OFFSET CH7	0000
OFFSET CH0	00000	SPAN CH7	01.000
SPAN CH0	01.000	ANALOG CH8	00000
ANALOG CH1	00000	OFFSET CH8	00000
OFFSET CH1	00000	SPAN CH8	01.000
SPAN CH1	01.000	ANALOG CH9	00000
ANALOG CH2	00000	OFFSET CH9	00000
OFFSET CH2	00000	SPAN CH9	01.000
SPAN CH2	01.000	ANALOG CH10	00000
ANALOG CH3	00000	OFFSET CH10	00000
OFFSET CH3	00000	SPAN CH10	01.000
SPAN CH3	01.000	ANALOG CH11	00000
ANALOG CH4	00000	OFFSET CH11	00000
OFFSET CH4	00000	SPAN CH11	01.000
SPAN CH4	01.000	ANALOG CH12	00000
ANALOG CH5	00000	OFFSET CH12	00000
OFFSET CH5	00000	SPAN CH12	01.000
SPAN CH5	01.000	ANALOG CH13	00000
ANALOG CH6	00000	OFFSET CH13	00000
OFFSET CH6	00000	SPAN CH13	01.000
SPAN CH6	01.000	ANALOG CH14	00000
		OFFSET CH14	00000
		SPAN CH14	01.000
		ANALOG CH15	00000
		OFFSET CH15	00000
		SPAN CH15	01.000

When analog tweaking is YES, each channel can be programmed with an offset and span value. Offset is an added value of +/- 500. Span is a multiplier of 0.900 to 1.100. The analog channel value is displayed for convenience in adjustment.

MARATHON SENSORS INC.

MULTIPRO ANALOG OUT MENU

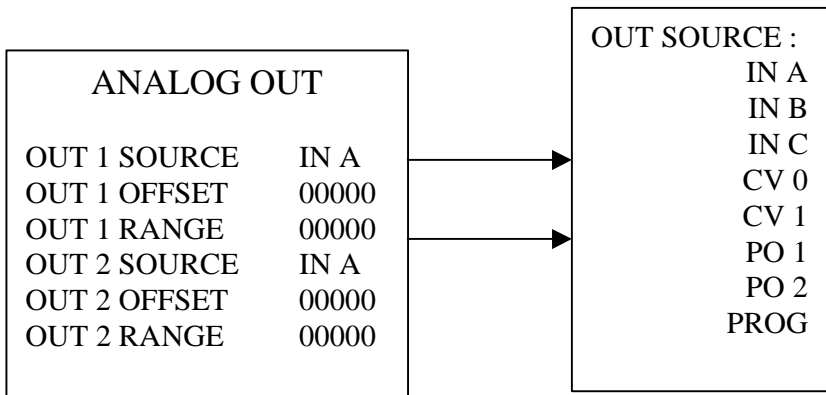

Standard Analog Output Valves are 0 - 5VDC or 0 - 20mA (selectable).

The IN A, B, C selection outputs a proportional signal relative to the actual value of A, B, or C over the zero to full scale range of the input.

PO 1 and PO 2 sets the output to the proportional percent output of control loop 1 or 2.

OFFSET and RANGE apply only to inputs A, B, C and CV 0 and 1 only.

PROG - This selection allows the logic program to directly write the analog output value.

MARATHON SENSORS INC.

MULTIPRO AUX COMMUNICATIONS MENU

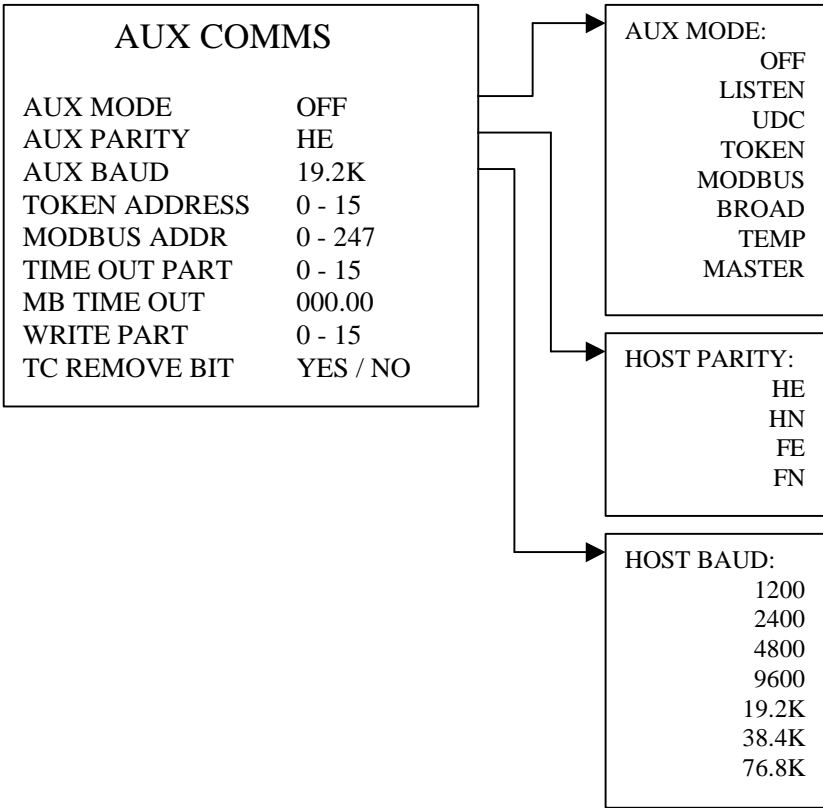

AUX MODE DESCRIPTION:

- LISTEN - MMI network monitor, controller updates slave table information sent over the this buss.
- UDC - communicates with honeywell udc controllers
- TOKEN - MMI network shared master. Allows buss control between multiple controllers at the master level.
- BROAD - setpoint is broadcast in 10pro protocol
- TEMP - temperature slave protocol for 10pro
- MASTER - MMI network master
- MODBUS - MODBUS master
- OFF - Does not initiate messages. Will respond as a MODBUS slave.

MARATHON SENSORS INC.

PARITY DESCRIPTION:

HE - half duplex / even parity

HN - half duplex / no parity

FE - full duplex / even parity

FN - full duplex / no parity

TIME OUT PARTITION and MB TIME OUT

The time out partition is used when a slow device is connected to the AUX port in Master or Token mode. The time out partition sets the channel address at which the master buss (MB) time out value takes effect. The MB time out value may be set from .01 sec to 2.5 seconds and determines the amount of time allowed for devices at the time out partition address or higher to respond. In token mode, all masters on the buss must be set for the same partition and MB time out value. For example, if the time out partition is set for 14 then devices at address 14 and 15 will be allowed extra time to respond as set by MB time out. A time out partition of 0 disables the time out feature.

WRITE PARTITION

The write partition sets the address at and above which the tables can be used for local variables. For example, if the write partition is set for 5 then tables 5 through 15 are considered local tables and the external devices are not polled. A write partition value of 0 disables this feature. Also the time out partition overrules the write partition. If the write partition is 5 and the time out partition is 14, then channels 1, 2, 3, 4, 14, and 15 are polled and tables 5 through 13 are considered local.

TC REMOTE BIT

The TC remote bit feature is for compatibility with older recipe programs. This value should be set to NO unless there is a need for this compatibility. When set to YES, if a slave temperature controller is in local mode, the bit 12 of the actual slave setpoint is set. This effectively adds 4096 to the setpoint value. Since the local/remote indication uses bit 13 of the percent output parameter, this feature is redundant and could be confusing.

MARATHON SENSORS INC.

MULTIPRO BASIC STATUS PAGE

BASIC STATUS

STATUS	STOP
PORT USAGE	ACTIVE

LINE NUMBER	0000
OPERATION CODE	

ERROR MSG:	OK
1998/06/09	10:27

This screen displays information on the BASIC program. The STATUS will indicate Stop for no program running, Run for a program running, or N.A. indicating that the BASIC is not available. The BASIC program can be controlled by pressing the enter key or the knob and selecting run or stop. No action will occur if N.A. is displayed. PORT USAGE indicates whether the port is active or in sleep mode for BASIC or that the port is being used as a temperature or host port.

MARATHON SENSORS INC.

MULTIPRO CALCULATIONS SETUP MENU

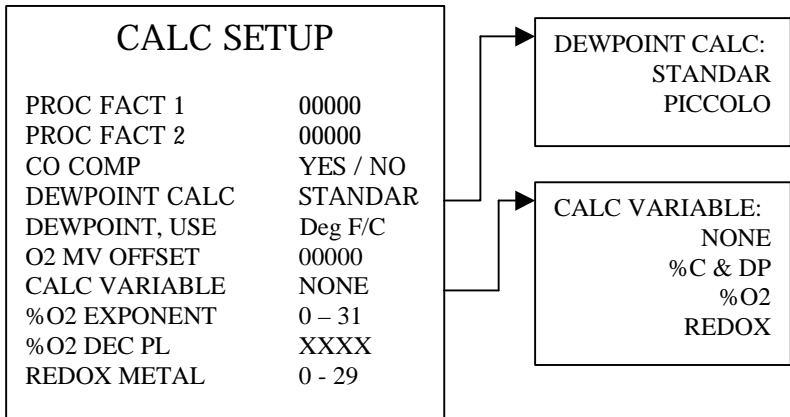

Process factor can be entered to adjust carbon potential calculation.

Co comp allows adjustment of the CO in the process factor calculation. This value can be read as input or as a programmed parameter. Value must represent the measure %CO.

%O2 Exponent can be set to 2 for Percent, 6 for parts per million, or as desired.

%O2 DEC PL determines resolution of displayed data.

Redox Metal selects which compensation curve is used. See the Redox Metals page for a list of loaded curves and the Redox Technical Background section.

MARATHON SENSORS INC.

MULTIPRO CALIBRATION MENU

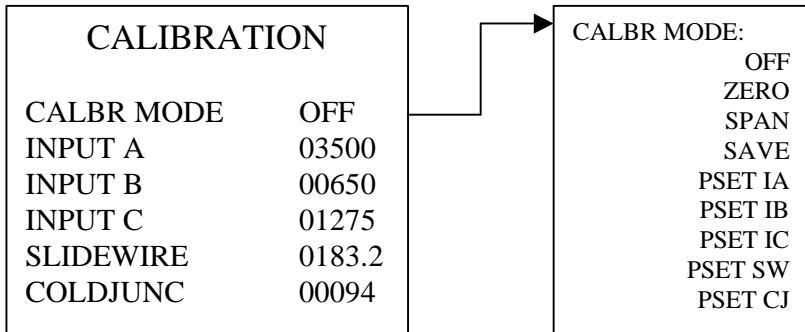

- Calbr mode Select the zero or span setting to calibrate either setting on all input channels or analog output channels. Input the zero or span signal to each channel and adjust the displayed value to match input value.
- Save Select save to save all the calibration value adjustments.
- Coldjunc Allows cold junction temperature adjustment. This is typically a factory adjustment.
- Factor Displays changing calibration factor for the selected inputs.
- PSET Loads a preset calibration value for the input or function selected. SW is for slidewire, CJ is for cold junction.

MARATHON SENSORS INC.

MULTIPRO CONTROL SETUP MENU

CONTROL SETUPS	
LOOP 1 MODE	DIR TP
LOOP 2 MODE	DIR TP
LP 1 VARIABLE IN	A
LP 2 VARIABLE IN	B
SW DEADBAND	0.2
EVENTS USED	YES

The 'CONTROL SETUPS' menu can be reached by pressing the 'GOTO' button twice and then rotating the 'KNOB' until the 'CONTROL SETUPS' is highlighted and pressing the 'KNOB' or 'ENTER' button..

MODE DESCRIPTION :

- TP - Time Proportioning
- TC - Time Proportioning with Complement (form C contact)
- TD - Time Proportioning Dual
- MS - Motor with Slidewire Feedback (Loop 1 only)
- MM - Multi Mode control (Loop 2 only)
- OF - On/Off Control
- OC - On/Off with Complement (form C contact)
- OD - On/Off Control Dual
- PP - Position Proportioning
- N/A - Turns control loop off

---NOTE---

See Output Contact Configuration Table for a description of how the control modes operate available contacts.

MARATHON SENSORS INC.

MULTIPRO DATA PAGE

DATA	
COLDJUNCTION	104
INPUT A	1200
INPUT B	2400
INPUT C	30
CALC VAL 0	0
CALC VAL 1	0
CALC VAL 2	0
CALC VAL 3	0
1998/06/09 03:07PM	

This page displays the realtime values of all inputs and calculated values. This is a display page only, no values can be changed.

CALC VAL 0 typically shows %C
CALC VAL 1 typically shows Dewpoint
CALC VAL 2 typically shows Oxygen
CALC VAL 4 application specific value typically not used

MARATHON SENSORS INC.

MULTIPRO DIGITAL EVENTS SETUP MENU

DIGITAL EVENTS

INT EVT PAR	0 - 4
# EXT EVT BDS	0 - 4
EVT BUSS RATE	1200 - 4800
DUAL BUSS	YES / NO
#UDC'S	0 - 8
EXT EVT 1 PAR	0 - 16
EXT EVT 2 PAR	0 - 16
EXT EVT 3 PAR	0 - 16
EXT EVT 4 PAR	0 - 16
EXT MAPPING	YES / NO

Multipro internal events can be mapped as inputs or outputs with the partition setting. A partition of 0 assigns all events as inputs, 2 would assign two outputs then two inputs if a total of four events are available.

Up to four external digital event boards can be added to the multipro (64 events total). The same partitioning scheme is available for external inputs / outputs.

Dual buss - allows temperature controls (half duplex) to share events buss with opto boards (full duplex). The #UDC's selection partitions the type of temperature controls between 10PRO's and UDC 3000's.

Event mapping - allows event channels to be mapped to program assignments.

MARATHON SENSORS INC.

MULTIPRO DIGITAL EVENTS PAGE

DIG EVENTS											
	0	1	2	3	4	A	B	C	D	E	F
0	0	0	0	0	0	0	0	0	0	0	0
1	0	0	0	0	0	0	0	0	0	0	0
2	0	0	0	0	0	0	0	0	0	0	0
3	0	0	0	0	0	0	0	0	0	0	0
4	0	0	0	0	0	0	0	0	0	0	0
		1	2	3	4						
COM	ST	B	B	B	B						

The operator can turn on / off individual events manually from this page. Realtime events 1-15 are shown as 0-F for five event groups 0-4. Event group 0 indicates the multipro internal events status. Only position 0 - 3 are valid. Event groups 1 - 4 indicate external digital event boards.

See the digital events setup menu for event board activation and partitioning.

Com st - communication status indicators for digital boards 1 - 4. B = bad communication status, ok = good communication status.

MARATHON SENSORS INC.

MULTIPRO EXTERNAL ANALOG DATA PAGE

EXT ANALOG

EXT I/O 0	00000
EXT I/O 1	00000
EXT I/O 2	00000
EXT I/O 3	00000
EXT I/O 4	00000
EXT I/O 5	00000
EXT I/O 6	00000
EXT I/O 7	00000
EXT I/O 8	00000
EXT I/O 9	00000
EXT I/O A	00000
EXT I/O B	00000
EXT I/O C	00000
EXT I/O D	00000
EXT I/O E	00000
EXT I/O F	00000

This page displays the realtime values of all 15 channels of the selected analog event board. The selected board is determined by the offset address value in the analog events setup page.

Values of outputs can be changed if a logic program is not setting them. Inputs can not be changed.

FILTER SETUPS

% C FILTER	NO
% C TIME	0000.1
DEWPT FILTER	NO
DEWPT TIME	0000.1

The Calculated percent carbon and dewpoint may be filter by activating sliding average filters. This screen is used to activate and set the filter time. The filter time is in minutes. The Multipro does not save any data when the filter is off; therefore, the full effect of the filter is not apparent until one filter time after the filter is activated.

MARATHON SENSORS INC.

MULTIPRO FRONT PANEL PAGE

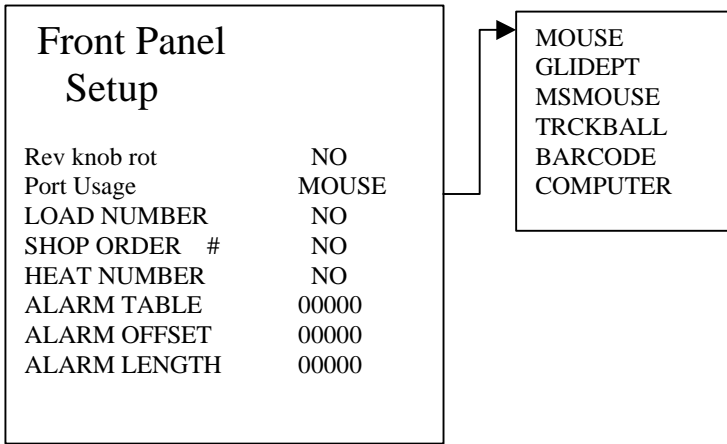

This screen is used for front panel options. The reverse knob rotation setting if set to yes will make a CW rotation of the knob go down through the menus. It will not change the direction when setting values. The port usage refers the 6 pin din connector on the front of the Multipro. The load number, shop order #, and heat number are options for the spec number entry database. The alarm table, offset, and length are used by the active alarms page. These values are usually set by the logic program.

MARATHON SENSORS INC.

MULTIPRO GENERIC DISPLAY PAGE

TBL	PAR	HEX	DEC
0D	93	0000	00000
.	.	.	.
.	.	.	.
00	79	0000	00000

The generic display is for diagnostic purposes.

MARATHON SENSORS INC.

MULTIPRO HOST COMMUNICATIONS MENU

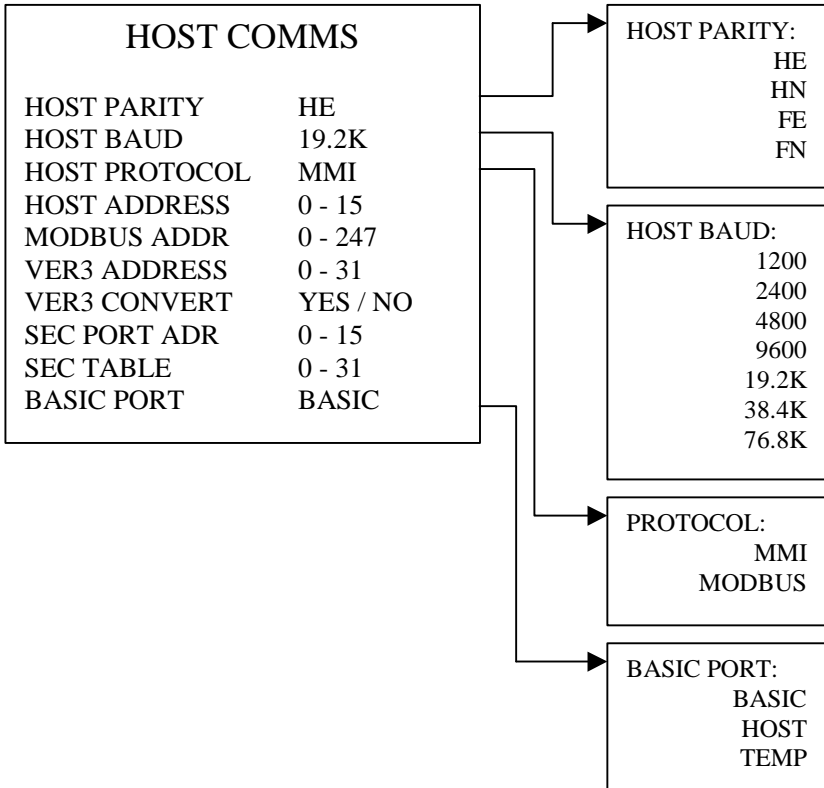

Parity description:

HE - half duplex / even parity

HN - half duplex / no parity

FE - full duplex / even parity

FN - full duplex / no parity

Basic port notes:

The basic port has a fixed baud rate of 4800 with full duplex 8 bit no parity. When basic is selected these conditions are fixed. If HOST or TEMP are selected conditions change to half duplex, 7 bit even parity. The baud rate remains 4800. HOST provides a second host port, TEMP provides a temperature buss for communications to Marathon 10 PRO instruments.

SEC PORT ADR - Secondary port address, allows the host port to respond to a second address with a different base parameter table. If 0 it is disabled.

SEC TABLE - Set the base table for the secondary port address.

MARATHON SENSORS INC.

INPUT SETUP

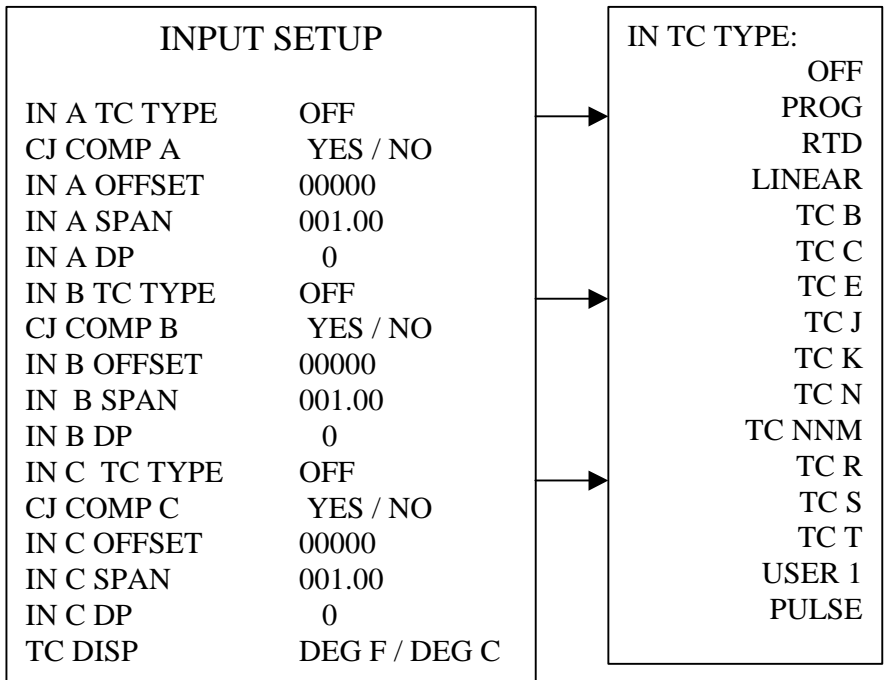

NON THERMOCOUPLE INPUT DESCRIPTION

- PROG** Allows the displayed value for the input to be scaled using offset and span values.
- LINEAR** Allows for a direct reading of most input levels up to 5VDC and 20mA.
- USER** Allows for user defined linearization curves. Values are setup in internal parameter tables using the instrument's BASIC programming feature.
- OFF** Turns the input off.
- PULSE** Use this selection when a pulse input board is installed. Use the pulse setup page to scale the input.

MARATHON SENSORS INC.

INPUT ADJUSTMENT

INPUT ADJUST		
ADJUST	A	NO/YES
A OFFSET		00000
A SPAN		01.000
ADJUST	B	NO/YES
B OFFSET		00000
B SPAN		01.000
ADJUST	C	NO/YES
C OFFSET		00000
C SPAN		01.000

The input adjust allows the operator to adjust the reading of instrument without changing the calibration. The adjust factor must be turned on by selecting YES from the adjust A (B or C). If no is selected then the offset and span values are ignored. If YES is selected the offset is subtracted from the input value and the result is multiplied by the span value, the range of the offset is +/- 2000. The range of the span is 0.800 to 1.200.

MULTIPRO LCD TEST



(SCREEN DISPLAYS
VARIOUS PATTERNS
DURING TEST)

End screen by pressing any key.

MARATHON SENSORS INC.

MULTIPRO LOCK/SERVICE PAGE

SERVICE	
LOCK LEVEL	3
SERVICE LEVEL	0
 Escape to default page for new lock level to activate.	

LOCK LEVEL		SERVICE LEVEL	
0	NO ACCESS	0	NO ACTION
1	LIMITED ACCESS	1	DEBUG LOGIC PROG. ON ANY ERROR
2	SOME RESTRAINTS	2	DISABLE PASSWORD
3	FULL ACCESS	3	DISABLE PASSWORD AND DEBUG LOGIC PROG

MARATHON SENSORS INC.

MULTIPRO LOGIC PROGRAM PAGE

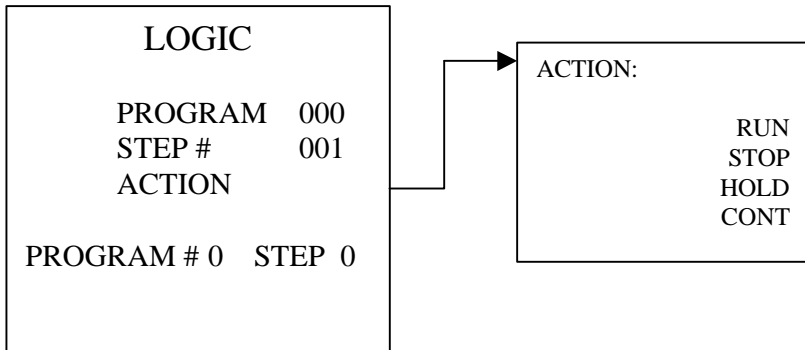

The logic program controls and monitors functions in the instrument that are not normally accessed by the operator. The operator can run / stop / hold / continue any logic program in the instrument. Programs can be started from selected step numbers in the program.

Program selection is based on program partition settings shown in the programmer menu. Typically the logic program is program 001.

The executing program and step number is displayed at the bottom of the screen.

MARATHON SENSORS INC.

MULTIPRO LOGIC EDIT SCREEN

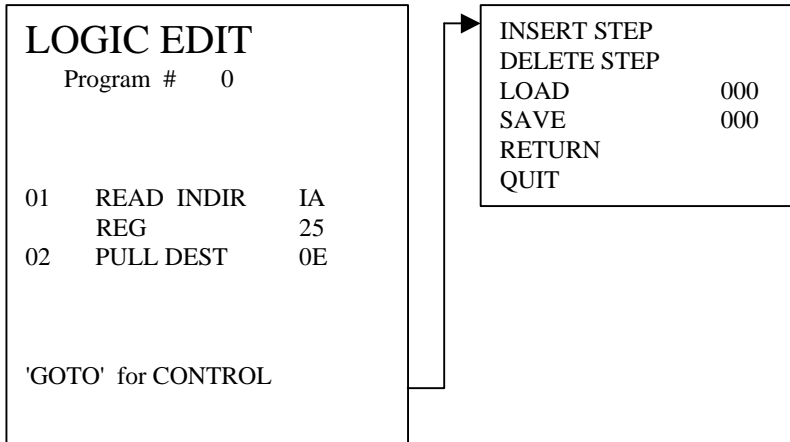

This screen is used to edit a logic program.
Pressing the 'GoTo' key provides a selection of edit and control features.

MARATHON SENSORS INC.

MULTIPRO LOGICAL EVENTS PAGE

LOGICAL EVENTS

0123456789ABCDEF
0 0000000000000000
1 0000000000000000
2 0000000000000000
3 0000000000000000
4 0000000000000000

EVT MAPPI NG NO

This page is only valid if events mapping is on (YES) .
The operator can turn on / off individual events manually from this page.
Realtime events 1-15 are shown as 0-F for four event group 0-3.

The event mapping assignments are made by the logic program and vary from application to application.

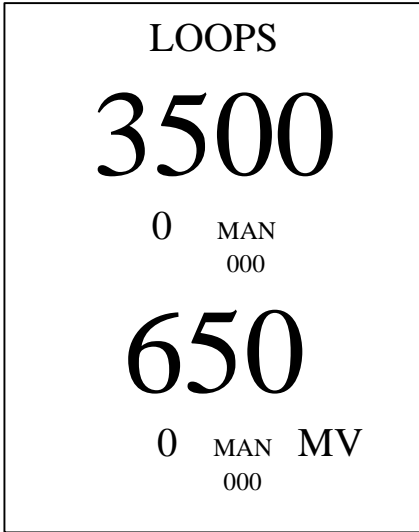

The loops display is an alternate way of display information on the two control loops. The main feature of the loops display is the quad high display of the process variables.

MARATHON SENSORS INC.

MULTIPRO LOOP TUNING

The loop 1 or loop 2 tuning menu can be reached by pressing the 'GOTO' button twice and then rotating the 'KNOB' until the 'LOOP 1 TUNING' or "LOOP 2 TUNING" is highlighted and pressing the 'KNOB' or 'ENTER' button..

LOOP 1 / 2	
PROCESS VAR	0000
SETPOINT	0
LOOP 1 / 2 MODE	AUTO/MAN
PERCENT OUT	00000
PROP BAND	00000
RESET	000.00
RATE	000.00
CYLCE TIME	00000
LOAD LINE	00000
HIGH LIMIT	00000
LOW LIMIT	00000

NOTE: PERCENT OUT can only be changed in MANUAL MODE. The actual output changes as the values change.

LOAD LINE (manual reset) provides an offset percent output.

MARATHON SENSORS INC.

MULTIPRO MASTER TIMER PAGE

MASTER TIMER

00000 MIN
UP/DOWN COUNTER

00HR 00MIN

'Enter' = Edit
'GoTo' = change
direction

This screen allows for displaying and editing of the recipe master timer. The time is set in minutes. The equivalent hours and minutes is displayed to assist the operator. To edit the value press 'Enter' or the knob. The displayed time will flash to indicate edit mode. Use the knob to adjust the time value. Press 'Enter' when the desired value is set. The master timer can be an up timer or a down timer. The 'GOTO' key can be used to toggle the direction of the timer.

MARATHON SENSORS INC.

MULTIPRO OPERATOR INPUTS PAGE

OPER INPUTS

REF NUMBER	00000
NUMBER 1	00000
NUMBER 2	00000
NUMBER 3	00000
NUMBER 4	00000
NUMBER 5	00000
NUMBER 6	00000
NUMBER 7	00000
NUMBER 8	00000
NUMBER 9	00000
NUMBER 10	00000
NUMBER 11	00000
NUMBER 12	00000
NUMBER 13	00000
NUMBER 14	00000
NUMBER 15	00000

These values can be changed by the operator to pass additional information to the logic program. They are similar to the reference number but require additional programming to use.

MARATHON SENSORS INC.

MULTIPRO PASSWORD ENTRY

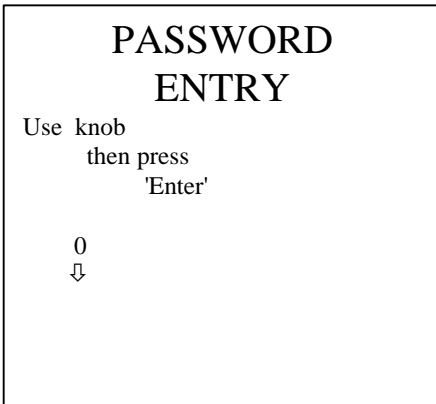
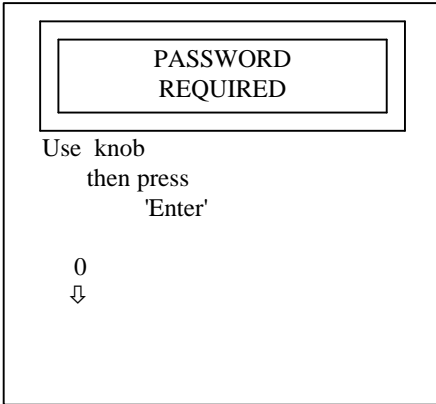

This screen is used to set the password. A password is always required to enter this screen.

This arrow indicate the direction the knob should be turned to enter the number. Down indicates CCW, up indicates CW. The number increments by one for each 'click' of the knob.

PRESET
MEMORY

PRESET MEMORY?

NO / YES

This screen is used to preset the Multipro memory to factory defaults. This should only be done if there has been an extreme disruption of memory. A password is always required to enter this screen.

MARATHON SENSORS INC.

MULTIPRO PROBE CARE DISPLAY

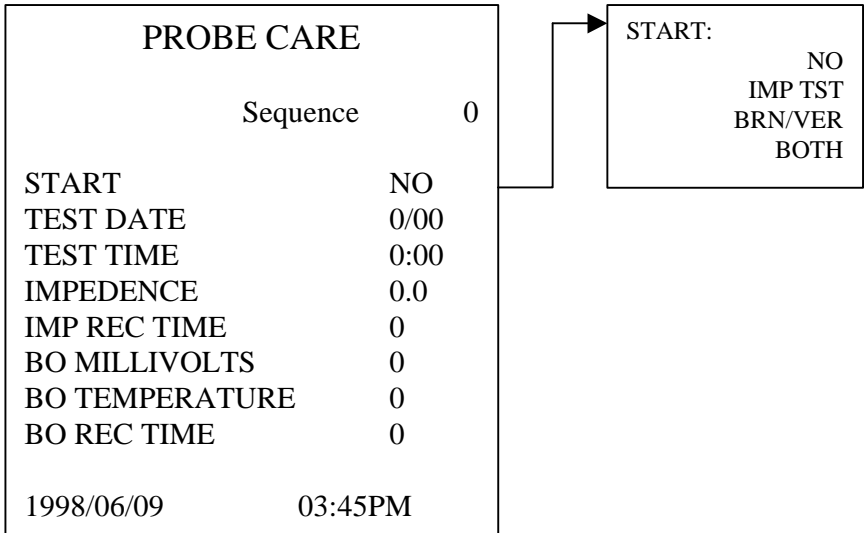

This display shows the latest probe care information from the last maintenance cycle. Impedence is calculated ohms, burn off recovery time is in seconds.

MARATHON SENSORS INC.

MULTIPRO PROBE MAINTENANCE MENU

PROBE MAINT

START	YES / NO
MAINT INTERV	00000
MAX PROBE IM	0000.0
IMP REC TIME	00000
BURN OFF TIM	00000
BURN REC TIM	00000
FINAL DELAY	00000
VER AVE 1	00000
VER AVE 2	00000
VER DEL 1	00000
VER DEL 2	00000
VER GAS	0000.0
VER TOL	0000.0
TEST INHIBIT	YES / NO

If the calculation variable is %O₂ then a probe maintenance function consists of a probe verification followed by a probe impedance test. Otherwise, the probe maintenance function is a probe impedance test followed by a probe burn off.

Start changed to yes will immediately start the probe maintenance function.

Maintenance interval - setup in minutes (9999 mins max). Probe maintenance is done from the time start is changed to yes and then at this interval until the function is inhibited.

Max Probe Imp - Set the alarm point on probe impedance.

Impedance recovery time - allows for a preset recovery time (seconds).

Burn off time - this period can be selected in seconds.

Final delay - allows for stabilization of the probe before control action resumes (seconds).

Test inhibit - disables the probe maintenance function.

MARATHON SENSORS INC.

Ver Ave 1 - Length of time in minutes the first and third average stages of a probe verification cycle.

Ver Ave 2 - Length of time in minutes of the second average stage.

Ver Del 1 - Delay time in seconds between first and second average.

Ver Del 2 - Delay time in seconds between second and third average.

Ver Gas - Percent of Oxygen in the reference gas used in verification.

Ver Tol - Tolerance allowed in verification test.

MARATHON SENSORS INC.

MULTIPRO PROBE VERIFICATION PAGE

PROBE		
VERIFICATION		
Sequence		0
START	NO	
TEST DATE		00/00
TEST TIME		00:00
VER GAS		0.0
VER TOL		0.0
VER RESULT		0.0
MAX IMP ALARM	NO	
VER ALARM	NO	
1998/06/09	11:30AM	

The results and setup of the last probe verification test are shown on this screen. The test can be started either as an impedance test, a verification test, or both.

MARATHON SENSORS INC.

MULTIPRO PROGRAMMER MENU

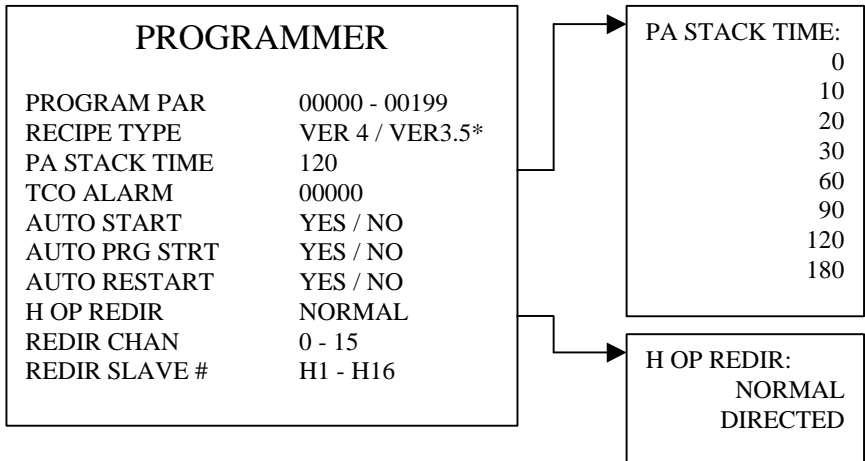

This screen is used to setup parameters related to logic programs.

- | | |
|-----------------------|--|
| Program par | Select which programs run as recipes and which run as logic programs. Program numbers above this number will run as recipe programs. Only applies if recipe program is selected as ver 4 type. |
| Recipe type | Select version 4 logic or ver 3.5 recipe language |
| Pa stack time | this is the number of seconds an alarm value is held so that process master can retrieve it. |
| Tco alarm | When enabled, this alarm compares the difference between the probe thermocouple and the temperature controller. This value should be the normal difference between the two readings. Disabled if 0. Activated by programming alarm 81, de-activated by programming alarm 85. |
| Auto prg strt (logic) | Yes setting allows logic program 1 to start at step 1 when power is applied to instrument. |
| Auto start (recipe) | Allows a recipe to continue running if power was lost and reapplied to the instrument. |
| Auto restart | Restarts logic program at program1 if it has stopped for more than 5 secs. |

MARATHON SENSORS INC.

H op redir H op code redirection, forces to which temperature controller the h opcode (temp setpoint) is applied (see Programming Manual).

Redir chan 0 = master multipro, 1 - 15 applies opcode to slave multipro.

Redir slave # Directs opcode to slave multipro's temp controllers 1-8.

VERSION 3.5 RECIPE PROGRAMMING COMMANDS

MNEMONIC	DESCRIPTION
ADD REFN	ADD TO THE REFERENCE NUMBER
ALARM	SOUND THE ALARM AND DISPLAY A MESSAGE
BRANCH	TEST PROGRAM CONDITIONS AND BRANCH
CARB SETP	SETS CARBON SETPOINT
CARB TEST	TESTS % CARBON FOR PREDETERMINED LEVEL
DELAY	DELAY PROGRAM EXECUTION BY SECONDS
EVENT	TURNS INTERNAL AND EXTERNAL OUTPUT EVENTS ON / OFF. WAITS FOR INPUT EVENT ON / OFF CONDITION.
FLAG	TURNS DIGITAL FLAGS ON / OFF TO DIRECT PROGRAM EXECUTION
GOSUB	ALLOWS ONE PROGRAM TO EXECUTE OTHER PROGRAMS SEGMENTS AND RETURNS TO ORIGINAL PROGRAM
IN A TEST	TESTS INPUT A VALUE TO PREDETERMINED VALUE
IN B TEST	TESTS INPUT B VALUE TO PREDETERMINED VALUE
IN C TEST	TESTS INPUT C VALUE TO PREDETERMINED VALUE
JUMP	ALLOWS PROGRAM TO JUMP TO ANOTHER PROGRAM WITH NO RETURN TO ORIGINAL
LIMIT	LIMITS THE AMOUNT OF TIME THE PROGRAM WILL WAIT FOR AN EVENT OR CONDITION
MTMR SET	MASTER TIMER SET
MTMR TEST	TESTS THE MASTER TIMER VALUE

MARATHON SENSORS INC.

NOP	NO OPERATION
	DESCRIPTION
MNEMONIC	TESTS CARBON CONTROL LOOP OUTPUT VALUE WITH A PREDETERMINED VALUE.
%C OUT	SPECIFIES THE TIME TO RAMP FROM THE CURRENT TEMP TO A NEW TEMP
RAMP	TESTS THE VALUE OF THE REFERENCE NUMBER
REFN TEST	SETS THE VALUE OF THE PROCESSS FACTOR
SET PROCF	SETS THE VALUE OF THE REFERENCE NUMBER
SET REFN	SOAK OF A SPECIFIED PERIOD OF TIME
SOAK	TESTS THE TEMPERATURE CONTROL LOOP OUTPUT VALUE WITH A PREDETERMINED VALUE.
TEMP OUT	CHANGES THE TEMPERATURE SET POINT
TEMP SETP	TESTS THE TEMPERATURE TO A PREDETERMINED VALUE
TEMP TEST	HOLDS PROGRAM FOR A SPECIFIED FLAG CONDITION
WAIT	IF FLAG 11 = OFF SET LOOP 2 SETPOINT IF FLAG11 = ON PASSES SETPOINT VALUE TO LOGIC PROGRAM
Z OPCODE	

PROGRAMS

LOAD #

RECIPE # 0 STOPPED
TIME LEFT: 0 MINS

LOGIC # 0 STEP 0

This screen displays the status of both the recipe and logic programs.

MARATHON SENSORS INC.

MULTIPRO PULSE SETUP PAGE

PULSE

* IN A VALUE	28000
* IN B VALUE	5205
* IN C VALUE	10206
IN A FACT	00.000
IN A PWR 10	-3
IN A DEC PL	XXXX
IN A UNITS	1/TIME
IN B FACT	00.000
IN B PWR 10	-3
IN B DEC PL	XXXX
IN B UNITS	1/TIME
IN C FACT	00.000
IN C PWR 10	-3
IN C DEC PL	XXXX
IN C UNITS	1/TIME

This screen is used to setup any pulse inputs. The realtime values of each of the three inputs is shown at the top of the page for convenience in setting the parameters. Only an input that has the TC type set as pulse will be affected by these setups. The FACT is a multiplier of the input pulse rate. The PWR 10 is a power of ten multiplier i.e. PWR 10 value of 2 is a multiplier of 100. The decimal place sets the display decimal location. The units value is either time or 1/time.

MARATHON SENSORS INC.

MULTIPRO RECIPE MENU

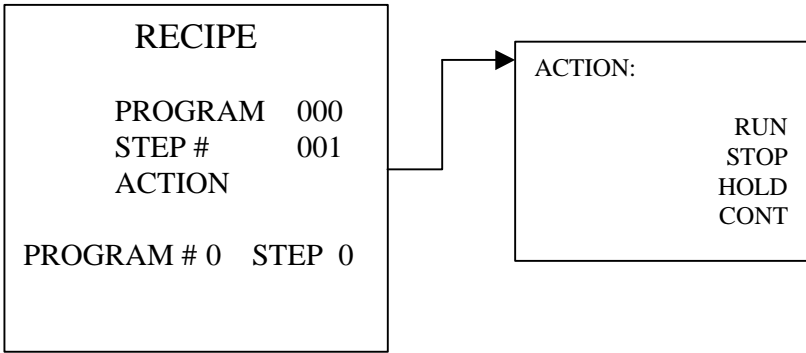

The operator can run / stop / hold / continue any recipe in the instrument.
Recipes can be started at selected step numbers.

The executing recipe and step number is displayed at the bottom of the screen and in the process screen.

MARATHON SENSORS INC.

MULTIPRO RECIPE EDIT PAGE

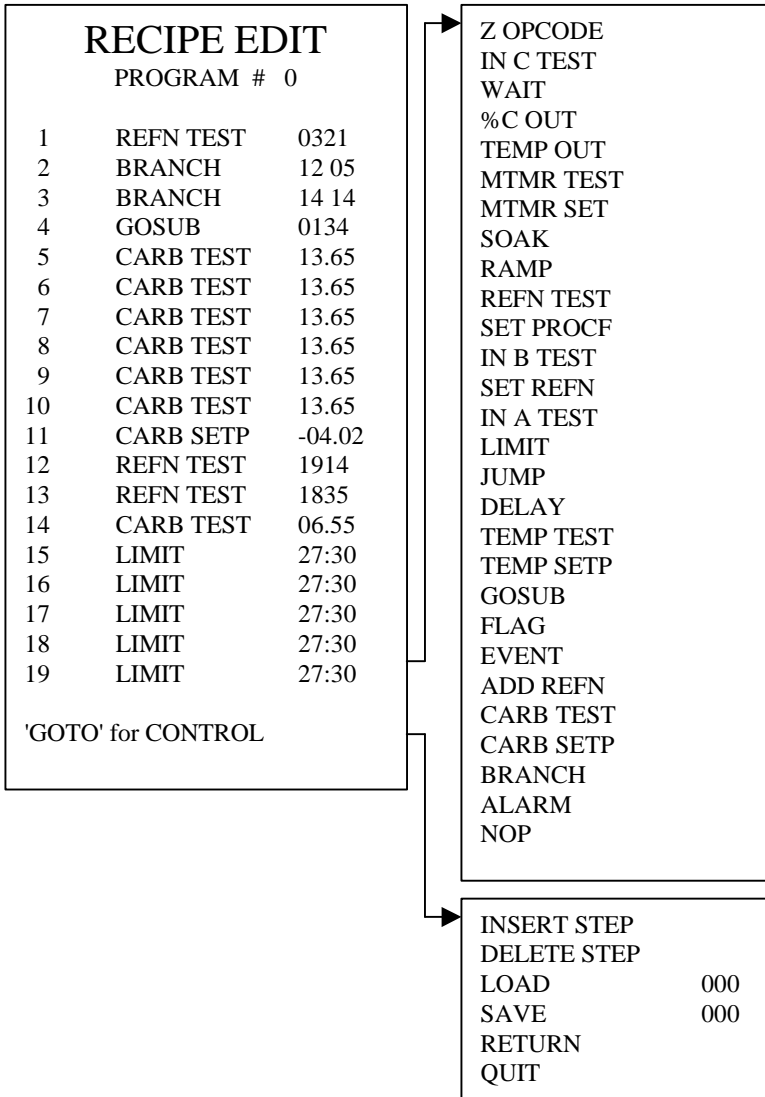

Pressing the 'GoTo' key provides a selection of edit and control features.
Only 8 lines show on screen . Use knob to scroll up or down program listing.

MARATHON SENSORS INC.

MULTIPRO REDOX METALS PAGE

	0	AL	15
R	1	Ca	16
E	2	Co	17
D	3	Cr	18
O	4	Cu	19
X	5	Fe	20
	6	Fe23	21
M	7	Fe34	22
E	8	Mg	23
T	9	Mn	24
A	10	Ni	25
L	11	Si	26
S	12	Ti	27
	13	V	28
	14	Zn	29

This screen list the metal reaction for each set of constants loaded in the Multipro.

See Redox Technical Background section for more information on Redox.

REACTION	MET#
$4/3Al+O_2=2/3Al_2O_3$	0
$2Ca+O_2=2CaO$	1
$2Co+O_2=2CoO$	2
$4/3Cr+O_2=2/3Cr_2O_3$	3
$4Cu+O_2=2Cu_2O$	4
$2Fe+O_2=2FeO$	5
$4Fe_3O_4+O_2=6Fe_2O_3$	6
$6FeO+O_2=2Fe_3O_4$	7
$2Mg+O_2=2MgO$	8
$2Mn+O_2=2MnO$	9
$2Ni+O_2=2NiO$	10
$2Si+O_2=2SiO$	11
$2Ti+O_2=2TiO$	12
$2V+O_2=@VO$	13
$2Zn+O_2=2ZnO$	14

MARATHON SENSORS INC.

MULTIPRO REMAINING TIME PAGE

<p>REMAINING TIME</p> <p>00000 MIN</p> <p>00HR 00MIN</p> <p>'Enter' = Edit</p>
--

This screen allows for displaying and editing the remaining time in a recipe SOAK, RAMP, or LIMIT. The time is set in minutes. The equivalent hours and minutes is displayed to assist the operator. To edit the value press 'Enter' or the knob. The displayed time will flash to indicate edit mode. Use the knob to adjust the time value. Press 'Enter' when the desired value is set.

MARATHON SENSORS INC.

MULTIPRO SET CLOCK PAGE

SET CLOCK	
YEAR	1998
MONTH	06
DAY	09
HOUR	09PM
MINUTE	30
WEEKDAY	TUE
SET NOW	YES/NO

This screen is used to set the internal clock calendar. To set the clock select each item and set it to the desired value. The minutes should be set to the next value. Select the SET NOW line and set yes. Press the knob or enter key just when the reference time reaches the next minute.

The operator can change the time displayed on the instrument. Values are not entered until the set now selection is set to yes and entered.

MARATHON SENSORS INC.

MULTIPRO SET DEFAULT PAGE

SET DEFAULT PAGE

00000

This screen is used to select which page will be the default page. If the value is 0 then the PROCESS page is the default. The number for a page is the number on the right hand of the screen after the page name on the FULL MENU.

MARATHON SENSORS INC.

MULTIPRO SETPOINTS PAGE

SETPOINTS

LOOP 1	00000
LOOP 2	00000
LOOP 1 MODE	MAN/AUTO
LOOP 2 MODE	MAN/AUTO

This screen allows for changing the loop setpoint values or control modes (auto/manual).

MARATHON SENSORS INC.

MULTIPRO SLAVE PAGE

SLAVE			
#ST	SP	ACT	PO
1	B	0	0
2	B	0	0
3	B	0	0
4	B	0	0
5	B	0	0
6	B	0	0
7	B	0	0
8	B	0	0

The communication status, temperature setpoint, actual temperature, and percent output of each slave temperature controller is displayed on this page. Comm status b = bad, ok = good, s = soft error.

MARATHON SENSORS INC.

MULTIPRO SLAVE STATUS PAGE

SLAVE STATUS					
	1	2	3	4	5
CSTAT	OK	B	B	B	B
VALID	OK	B	B	B	B
	6	7	8	9	A
CSTAT	B	B	B	B	B
VALID	B	B	B	B	B
	B	C	D	E	F
CSTAT	B	B	B	B	B
VALID	B	B	B	B	B

The slave status screen shows information about the slave instruments when the aux port is in master or token mode. CSTAT will show OK for a channel if it is communicating or the channel is in the write partition. VALID as OK indicates that a Dualpro or Multipro is connected to the aux port at that address.

MARATHON SENSORS INC.

SLIDE SHOW

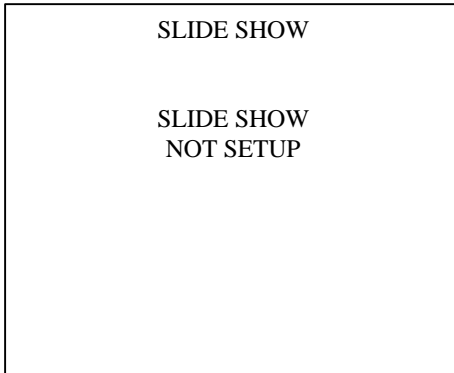

The slide show screen is used to sequence through up to eight screens. The SLIDE SHOW SETUP screen is used to define which screens are displayed and the delay between screens. The SLIDE SHOW page number can be set as the default page.

SLIDE SHOW SETUP

SLIDE SHOW SETUP	
Delay	00003
Screen 1	00001
Screen 2	00001
Screen 3	00029
Screen 4	00000
Screen 5	00000
Screen 6	00000
Screen 7	00000
Screen 8	00000

The slide show setup screen is used to define the slide show screen. The delay is the time in seconds (1 to 250). A delay value of 0 defaults to 3 seconds. The screens are selected by entering the page number from the FULL MENU display. To display a screen for a longer period than the other screens, then enter the page number under two sequential screens. The screens are displayed in order from screen 1 to screen 8. If the entry is 0 for a screen then the cycle restarts at screen 1. The slide show can be from 1 to 8 screens long. The first 0 entry determines the number of screens displayed.

MARATHON SENSORS INC.

MULTIPRO SOFT ALARM DIR PAGE

SOFT ALARM DIR	
DIR #	ALARM #
001	00000
.	.
.	.
200	00000

This screen is used to view the soft alarms. The two columns of numbers are the directory number and the alarm number stored in that location. If the alarm number is 0 then no alarm text is stored. The alarm text can be viewed by pressing the knob or the 'enter' key when the entry is selected. The text entries may be scrolled through by rotating the knob. Pressing the knob or the 'enter' key will toggle between the directory list and the text display. Alarm text can be entered into the instrument using the Process Master 6 program SETALM.

MARATHON SENSORS INC.

MULTIPRO SPEC # ENTRY PAGE

SPEC #	ENTRY
—	
'Enter'	= next
'GoTo'	= accept
'Esc'	= back

The SPEC # Entry screen is used to manually enter values into the spec number database. The spec number may have Rotate the knob until the desired character is displayed then press the knob or 'enter'. The maximum length allowed is 16 characters. When the maximum number of characters has been entered, the is this correct question will appear. To terminate entry before the maximum is reached, press the 'GOTO' key. The text characters are in the following order starting with a space: !"#%&'()*+,-

./@ABCDEFGHIJKLMN O PQRSTU VWXYZ`abcdef

ghijklmnopqrstuvwxy{|}~ . If the number that is entered existed then the operator has to chose to delete the spec number, reenter the number, or edit the data associated with the spec number. For a new number or editing a number, the operator is asked for the recipe, step, table, parm, and value. The recipe and step indicate what program should be run when this spec number is selected. The table, parm, and value provide for optionally setting a specific parameter to a value when the program is run. Normally these items are set to zero so that they are ignore. After the last item is enter the 'ACTION' question appears allowing the operator to save the data or abort.

Spec number text and program data can also be entered into the instrument using Process Master 6 program SETPART.

MARATHON SENSORS INC.

SPEC # SELECT

```
          SPEC #
          SELECT

PART NO 1
PART NO 2
ETC.
```

The Spec # select page is a multi-screen operation. First the operator is shown a list of part numbers in the database. The operator selects a part number and presses ENTER. The load number screen then appears.

```
SPEC NUMBER
XYZ
LOAD NUMBER

-----
RECIPE      1
STEP        1
```

The operator enters the load number and presses ENTER. The confirmation screen appears.

```
PART NUMBER
XYZ
LOAD NUMBER
1234
RECIPE      1
STEP        1
IS THE ABOVE CORRECT?
YES
```

MARATHON SENSORS INC.

Load number entry is enabled from the Front Panel menu. This entry can be labeled as "LOAD NUMBER", "SHOP ORDER NUMBER", or "HEAT NUMBER."

The operator then selects YES or NO and presses ENTER. The action complete message appears when the program has been started. Pressing ENTER or ESC will clear the action complete screen.

MARATHON SENSORS INC.

MULTIPRO TEXT DISPLAY PAGE

TEXT DISPLAY

TREND 1 TITLE

.

.

TREND 8 TITLE

CH 1 NAME

.

.

CH 12 NAME

RECIPE TITLE

LOGIC TITLE

GENERAL MSG 1

GENERAL MSG 2

PV LABEL N/A

PV LABEL INP A

PV LABEL INP B

MV

PV LABEL INP C

PV LABEL CV 0

%C

PV LABEL CV 1

DP

PV LABEL CV 2

%O

PV LABEL CV 0

This screen allows all the entered text to be viewed easily.

MARATHON SENSORS INC.

MULTIPRO TEXT ENTRY PAGE

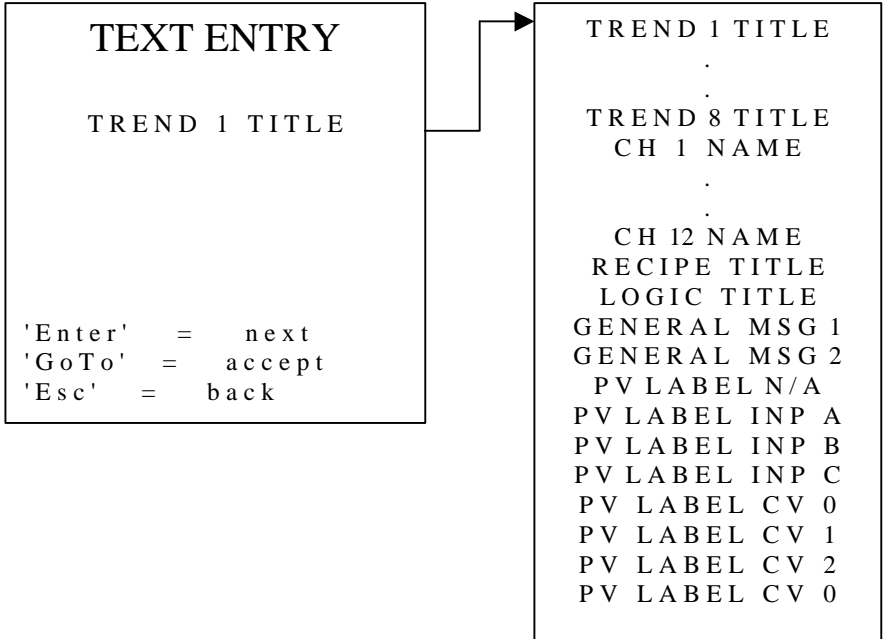

This screen is used to enter text messages into the Multipro IR. First select the text item to be entered by rotating the knob until the desired item is listed then press the knob or 'enter'. If a previous text entry had been stored it will appear otherwise the line is blank. Rotate the knob until the desired character is displayed then press the knob or 'enter'. The length allowed for the text item depends on the type of item i.e. channel names can only be 4 characters. When the maximum number of characters has been entered, the is this correct question will appear. To terminate entry before the maximum is reached, press the 'GOTO' key. The text characters are in the following order starting with a space: !"#S%&'()*+,-./@BCDEFGHIJKLMNOPQRSTUVWXYZ abcdefghijklmnopqrstuvwxyz{|}~ . The degree symbol is the last character on the list.

MARATHON SENSORS INC.

MULTIPRO TIMERS DISPLAY PAGE

TIMERS	
TIMER 0	00000
TIMER 1	00000
TIMER 2	00000
TIMER 3	00000
TIMER 4	00000
TIMER 5	00000
TIMER 6	00000
TIMER 7	00000
TIMER 8	00000
TIMER 9	00000
TIMER A	00000
TIMER B	00000
TIMER C	00000
TIMER D	00000
TIMER E	00000
TIMER F	00000

This screen allows for viewing or changing the general purpose timers. The operator has the ability to view and edit the 16 timers available in the multipro.

MARATHON SENSORS INC.

MULTIPRO TREND 1 - 8 DISPLAY

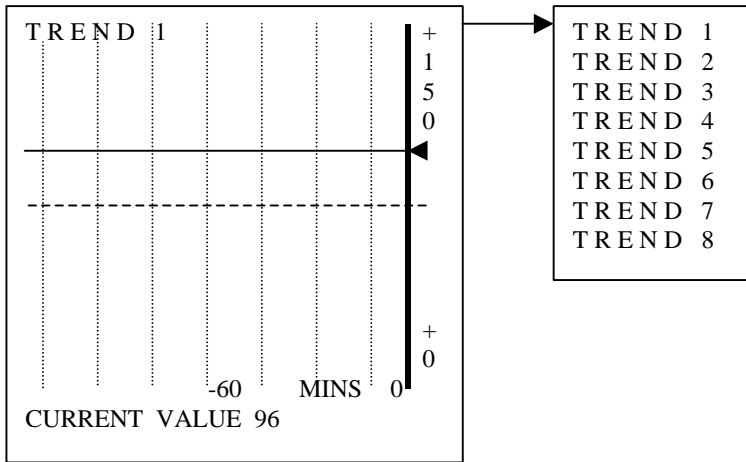

These screens show the trend data stored in the instrument. The knob can be used to scroll back and view older data. Near the bottom of the screen is the current data and relative time in minutes. The numbers on the right define the scaling range of the grid. The message title at the top can be changed with the text entry screen. Pressing the knob jumps to the trend zoom screen for the trend. The zoom allows up to a 20 to 1 compression of the time.

MARATHON SENSORS INC.

MULTIPRO TREND SETUP PAGE

This screen is used to setup the trend charts. The data to trend is defined by its parameter table and number. The sample interval is in minutes. The zero value and full scale value define the window of data to be displayed on the trend. The trend display resolution is 100 pixels. Therefore, if trending temperature with a zero value of 0 and a full scale of 2000, each pixel would represent 20 degrees. If a fine resolution was desired the range could be narrowed. For example if the normal operating temperature was 1650, then a zero value of 1600 and a full scale of 1700 would provide a 1 degree resolution per pixel.

TREND SETUP	
Values in decimal	
Sample int in min.	
CLEAR TREND #1	YES/NO
.....	
THROUGH	
CLEAR TREND #8	YES/NO
1 TABLE #	00000
1 PAR #	00000
1 DEC PT LOC	0
1 SAMPLE INT	0001.0
1 ZERO VAL	00000
1 FS VALUE	00000
2 OVER 1	NO
FLASH OVER	NO
THROUGH	
8 TABLE #	00000
8 PAR #	00000
8 DEC PT LOC	0
8 SAMPLE INT	0001.0
8 ZERO VAL	00000
8 FS VALUE	00000

The clear trend section erases any data in the trend memory so that it will not be confused with the real data.

Table # and parameter # select the item to be displayed on a trend plot. The decimal point location is used for display of the data.

MARATHON SENSORS INC.

Sample interval sets the trend axis in minutes.

Zero value sets the minimum value on the trend display.

Fs value sets the maximum full-scale value on the trend display.

Trends can be labeled now (see text entry menu)

The 2 over 1 (4 over 3, etc.) selection allows displaying two trends on the same screen. When 2 over 1 is YES, then trend 2 is displayed with trend 1 on the trend 1 display. When flash over is YES, then trend 2 flashes when being displayed over trend 1.

MARATHON SENSORS INC.

MULTIPRO TREND 1 - 8 ZOOM

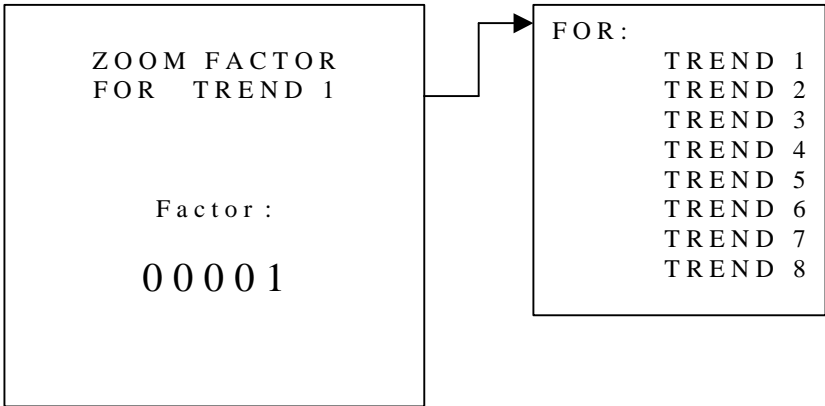

Multipro

Dualpro
Ver 4 Revision 126

Smart Interface
Ver 1 Revision 22

Screens
Ver 1.17 Standard

1998/06/09 07:27AM

This display shows the firmware revisions of the cpu board, display interface board, and screen text.

MARATHON SENSORS INC.

MAINTENANCE AND TROUBLESHOOTING

HOW TO CHANGE BOARDS FUSES AND ELECTRONICS SAFELY

Boards

Observe all electrical safety standards when handling the Multipro. Turn off or remove the power connection before handling any of the boards and work on a grounded surface with electrostatic defusion equipment. Use the following chart to identify the location of your boards. To troubleshoot a malfunction it is often necessary to exchange (swap) boards. Using proper grounding precautions, open the front panel using the knob at the bottom. Turn off the power. Turn off the triac/relay board switch.

Remove the board that may be causing the problem and exchange it for a new one.

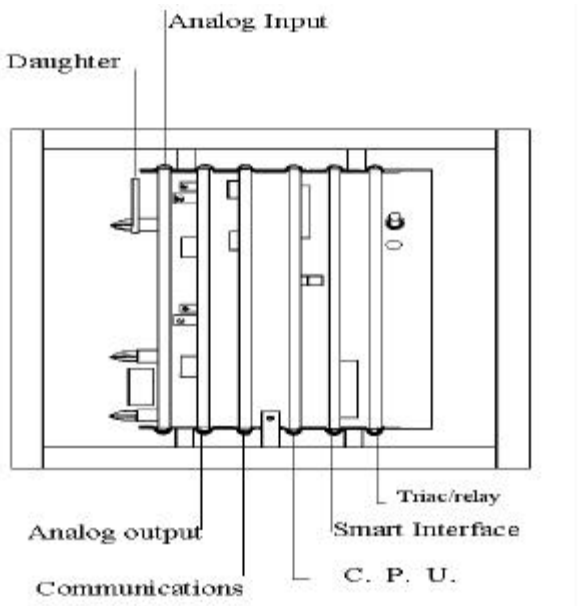

***** **WARNING** *****

All power MUST be removed from the rear of the instrument before triac board can be removed!!!!

MARATHON SENSORS INC.

FUSE

If the problem involves power to the instrument itself, first check that the instrument is connected to the power source correctly. If that is not the problem, then check the fuse on the Triac/relay board. The figure below will help locate the fuse.

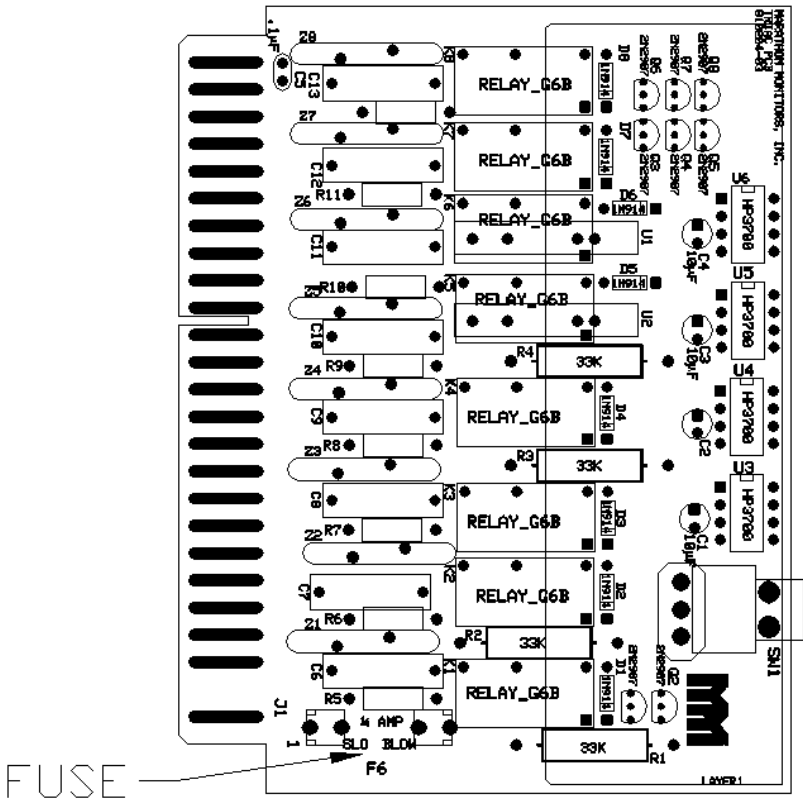

***** WARNING *****

All power MUST be removed from the rear of the instrument before triac board can be removed!!!!

MARATHON SENSORS INC.

PASSWORD PROTECTION

Security Levels:

- Highest 0 = Password always required
1 = Lock Level 3
2 = Lock Level 2 or above
3 = Lock Level 1 or above
4 = Lock Level 0 or above
Lowest 5 = always accessible

Screen	Security Level	Page ID	Page #	Screen	Security Level	Page ID	Page #
PROCESS	4	000	000	PROBE CARE	3	PVF	038
ACTIVE ALARMS	5	AAD	001	PROGRAMMER	1	L13	039
ALARM DISPLAY	4	ALM	002	PROGRAMS	3	PRG	040
ALARM 1 SETUP	1	L05	003	PULSE SETUP	2	PUL	041
ALARM 2 SETUP	1	L06	004	RECIPE CONTROL	3	SRP	042
ANALOG EVENTS	1	L15	005	RECIPE EDIT	1	ERP	043
ANALOG EVENTS O/S	1	AOS	006	REDOX METALS	5	RDX	044
ANALOG OUT	1	L07	007	REMAINING TIME	3	RT	045
AUX COMMS	1	L10	008	SET CLOCK	2	CLK	046
BASIC STATUS	1	BAS	009	SET DEFAULT PAGE	1	DFP	047
CALCULATIONS	1	L08	010	SETPOINTS	3	L01	048
CALIBRATION	1	CAL	011	SLAVE	3	SLA	049
CONTROL SETUPS	1	L04	012	SLAVE STATUS	3	BSL	050
DATA	3	DAT	013	SOFT ALARM DIR	5	SAD	051
DIGITAL EVENTS	1	L14	014	SPEC # ENTRY	1	SNE	052
DIG EVENTS	2	DIG	015	SPEC # SELECT	3	PNS	053
EXT ANALOG	2	AEV	016	TEXT DISPLAY	5	TXD	054
FILTERING	1	FIL	017	TEXT ENTRY	1	TXT	055
FRONT PANEL	2	FPS	018	TIMERS	2	TMR	056
GENERIC DISPLAY	1	GEN	019	TREND1 DISPLAY	3	TR1	057
HOST COMMS	1	L09	020	TREND2 DISPLAY	3	TR2	058
INPUT SETUP	1	L16	021	TREND3 DISPLAY	3	TR3	059
INPUT ADJUST	2	L18	022	TREND4 DISPLAY	3	TR4	060
LCD TEST	3	LCD	023	TREND5 DISPLAY	3	TR5	061
LOCK/SERVICE	0	LCK	024	TREND6 DISPLAY	3	TR6	062
LOGIC CONTROL	1	SLP	025	TREND7 DISPLAY	3	TR7	063
LOGIC EDIT	1	ELP	026	TREND8 DISPLAY	3	TR8	064
LOGICAL EVENTS	2	LOG	027	TREND SETUPS	2	L17	065
LOOPS	4	Q01	028	TREND 1 ZOOM	3	TZ1	066
LOOP 1 TUNING	2	L02	029	TREND 2 ZOOM	3	TZ2	067
LOOP 2 TUNING	2	L03	030	TREND 3 ZOOM	3	TZ3	068
MASTER TIMER	3	MT	031	TREND 4 ZOOM	3	TZ4	069
OPERATOR INPUTS	3	L12	032	TREND 5 ZOOM	3	TZ5	070
OPERATOR MENU	4	M01	033	TREND 6 ZOOM	3	TZ6	071
PASSWORD ENTRY	0	PSW	034	TREND 7 ZOOM	3	TZ7	072
PRESET MEMORY	0	PSM	035	TREND 8 ZOOM	3	TZ8	073
PROBE CARE	3	PRB	036	VERSION	5	VER	074
PROBE MAINT	2	L11	037	GOTO	2	GO	075

MARATHON SENSORS INC.

TECHNICAL BACKGROUND

The oxidation and reduction of metals

Metals react with oxygen in air to form metal oxides via an equation:

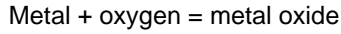

Metals, represented by M in the following equations, can react to form a variety of different types of oxides depending on the metal's electronic configuration.

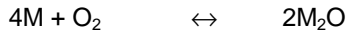

MARATHON SENSORS INC.

And metal oxides can react with oxygen in air to form more complex oxides such as:

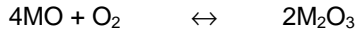
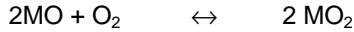

As these reactions occur from left to right, where oxygen is reacting with a metal or oxide, it is called **OXIDATION**. These reactions can also be forced to move from right to left, where a metal oxide converts back into an elemental metal and the oxygen is released. This process is called **REDUCTION**. Each metal and metal oxide combination have a specific oxygen level where they are in equilibrium with each other. At this specific oxygen level, no additional metal will be oxidized and no existing oxide will be reduced. The two sides of the reaction are in equilibrium with each other. In the ReDox controller, we call this the **NEUTRAL POINT**. The oxygen level which produces this neutral condition varies linearly as a function of temperature.

Thermodynamics of Metals

The 1840's were an exciting time for metallurgical development. This included the work of H. J. T. Ellingham (1) who's analysis of the empirical data associated with the oxidation and reduction of oxides and sulfides, helped set the foundation of present day metallurgical thermodynamics. He found that the relationship between the amount of energy required to change a metal into an oxide, or an oxide back into a metal, is a linear function of temperature. Richardson and Jeffes (2) superimposed an oxygen partial pressure scale to the Ellingham diagram, which gives us a very useful tool for predicting, monitoring and controlling atmospheres. The Ellingham diagram is shown on the next page.

MARATHON MONITORS INC.

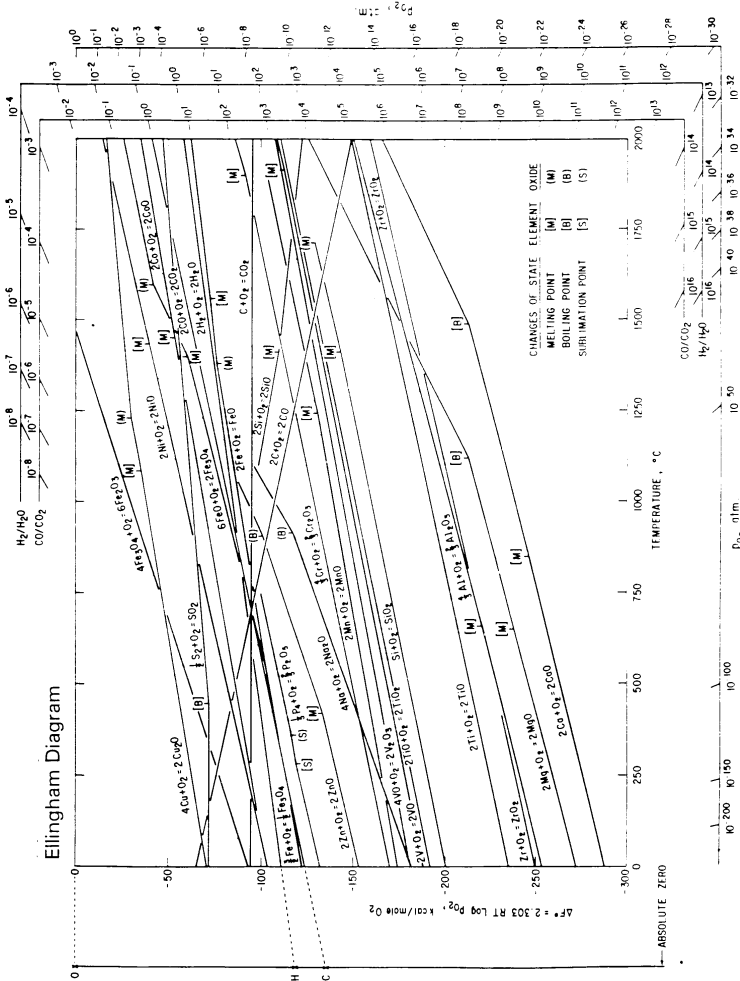

The diagram plots the equilibrium lines for the metal-metal oxide reactions as a function of the energy required to drive these reactions and the reaction temperature.

The equilibrium lines represent the **NEUTRAL POINT** of the metal-metal oxide reactions. If the thermal treating atmosphere lies directly on this

MARATHON SENSORS INC.

line, the atmosphere will be neither oxidizing or reducing to the metal. If the atmosphere lays above the line, the atmosphere will be oxidizing. Below the line it will be reducing. This is shown schematically in Figure 2A.

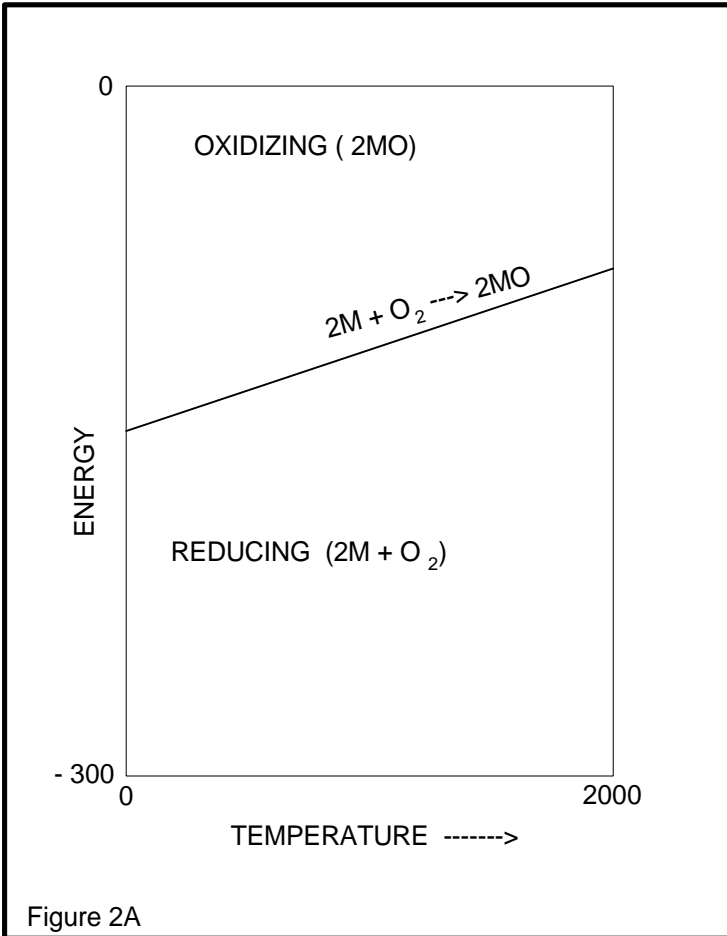

UNDERSTANDING THE ELLINGHAM DIAGRAM

The Equilibrium between Metals and Metal Oxides

The lines on the diagram denote where the elemental metal and metal oxide are in equilibrium with each other. That is, where no additional oxide will be formed and no oxides will be reduced back to their metal state. The position of these lines (how negative they are on the diagram) provides some information about how easy or difficult the reaction is to

MARATHON SENSORS INC.

reverse. Looking at the diagram, the reactions that are the most negative (those that are the lowest on the diagram) create the most stable oxides. These reactions include the formation of calcium oxide, magnesium oxide, alumina, titanium oxide/titanium dioxide, and silica. From practical experience, these oxides are regarded for their stable structures, even at elevated temperatures. We know that they are used in such applications as high temperature firebrick, paint pigments, glassmaking, and ceramics. Figure 3a shows schematically that these elements have a large area in the oxidation range and a small area in the reducing range. These oxides form readily and are difficult to reduce back to their elemental state.

Find the metal-metal oxide reaction lines toward the top of the diagram such as copper, iron, nickel, carbon, and cobalt. The Figure 3b diagram shows these metals as having a relatively small oxidizing area and a large reducing area. From practical experience, some of these metals oxidize readily at room temperature, others do not. They all will oxidize in air at some elevated temperature. But all of these, with the appropriate heat treating atmosphere, can be kept clean of oxides.

The metal-metal oxide reactions in the center of the diagram are chromium, manganese and vanadium. All oxidize under room temperature conditions. Appropriate atmospheres can be produced to keep these oxides from forming or from growing in thickness. The oxygen level must be kept to a very low level, or partial pressure, to avoid oxidation. See Figure 3c.

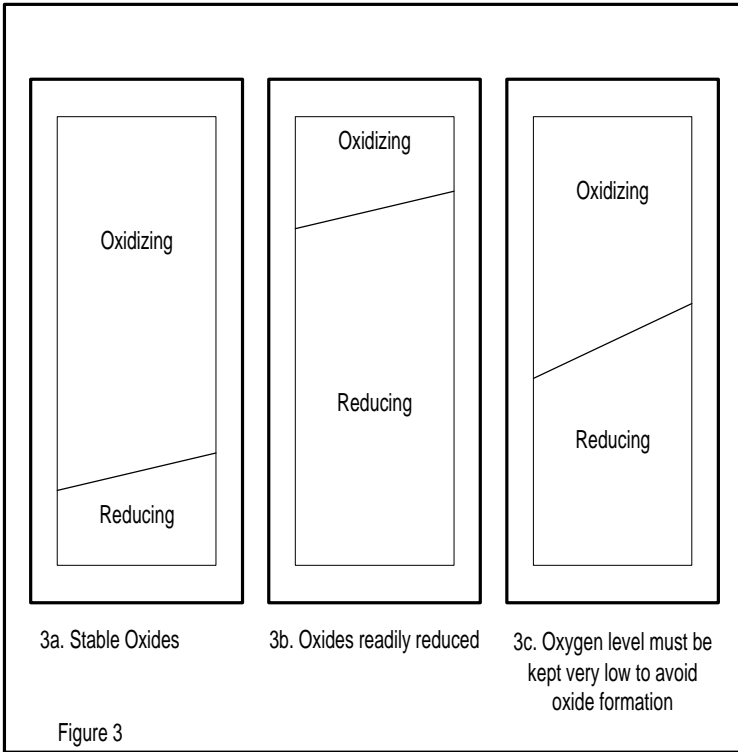

MARATHON SENSORS INC.

The Role of Oxygen

The research work of Richardson and Jeffes (2) makes it easy for us to determine how much oxygen is in equilibrium with the metal-metal oxide reaction. Here's how it is done.

Find your processing temperature on the x-axis of the chart.

Draw a vertical line at that temperature from the bottom to the top of the chart.

Determine your metal of interest for the alloy system to be analyzed.

This will typically be the element in the alloy that is lowest (most negative) on the diagram.

Place one end of a ruler on the zero point of the absolute zero scale.

Make sure that you are on the absolute zero scale and not on the corner of the diagram!

Pass the ruler through the point where the vertical temperature line and the metal-oxide reaction line intersect.

The point at which the ruler intersects the PO_2 , atm line, is the equilibrium oxygen level for the reaction.

MARATHON SENSORS INC.

Some examples are in the table below:

<u>Element</u>	<u>Temperature</u>	<u>Equilibrium Oxygen Level</u>
Copper	1800 °F	5×10^{-7}
Nickel	1800 °F	1×10^{-10}
Iron	1800 °F	1×10^{-15}
Chromium	1800 °F	1×10^{-22}

Each of these oxygen levels is very low. From practical experience, each of these metals will oxidize when heated in air even at 1000 °F. Each will also oxidize when heated in standard cryogenic grade nitrogen, although not as much as in air. The oxygen level in cryogenic nitrogen is approximately 10^{-6} . (10 ppm = 0.0001% = 10^{-6} on the chart) This is the reason that natural gas, hydrogen or some other type of scavenging or reducing gas is added to nitrogen for clean, bright parts.

You might notice that some of the lines exhibit inflections points, slight changes in direction. When the metal changes to a different phase or goes through a change of state (such as melting or vaporizing), the equation associated with this linear relationship changes, but it stays linear.

This equilibrium oxygen measurement is readily detected by the zirconia oxide sensor in the oxygen probe. This probe responds to the oxygen level by generating a millivolt signal which then travels to the ReDox controller.

MARATHON SENSORS INC.

HOW THE ReDox CONTROLLER DETERMINES THE NEUTRAL LINE

In the Ellingham diagram, the equilibrium oxygen content can be determined as it was described in the prior examples, or it can be determined mathematically based on the equation of the metal-metal oxide equilibrium line, or NEUTRAL LINE. The equation is a straight line function of the log of the partial pressure of oxygen and temperature. We can follow the following equations to calculate the millivolt reading for the neutral line of a given metal.

From the Nerst Equation, which governs the operation of oxygen probes, we know that

$$\% O_2 = \frac{\% O_2 \text{ ref.}}{10^{(E/0.0496 + Tk)}}$$

Taking the logarithm of this equation:

$$\log (\%O_2) = \log (\%O_2 \text{ ref.}) - E / (0.0496 + Tk)$$

Assuming $\% O_2 \text{ ref.} = 1$ atmosphere

Then $\log (\% O_2 \text{ ref.}) = 0$

And

$$\log (\%O_2) = - E / (0.0496 + Tk)$$

So we can rewrite the equation to solve for $\log (\%O_2)$ as a function of Temperature in the form of the equation for a straight line:

$$\log (\% O_2) = mTk + b$$

and

$$- E/0.0496 + Tk = mTk + b$$

So the controller solves for E, the millivolt signal associated with the neutral line, as a function of temperature:

$$E = - 0.0496 m Tk^2 - 0.0496 b Tk$$

This neutral condition is assigned a process value of zero in the controller. A process variable called the REDUCTION POTENTIAL

MARATHON SENSORS INC.

indicates how far the oxygen level (millivolt signal) of the atmosphere deviates from the neutral condition. A positive REDUCTION POTENTIAL indicates the atmosphere is reducing. A negative REDUCTION POTENTIAL indicates the atmosphere is oxidizing.

MARATHON SENSORS INC.

SOME APPLICATIONS AND EXAMPLES

In general, the system works as follows:

1. The operator inputs the type of metal being processed.
2. The oxygen probe provides temperature and oxygen level information via millivolt signals to the controller.
3. Based on the information from 1. and 2., the controller determines the millivolt reading associated with the NEUTRAL LINE and the

REDUCTION POTENTIAL

The REDUCTION POTENTIAL can be used as a setpoint variable for the process to run in an oxidizing or a reducing condition

If running a MONITORING SYSTEM, an alarm condition would notify the operator if the REDUCTION POTENTIAL was out of range.

If running a CONTROLLING SYSTEM, the flow controls would take steps to correct the deviation.

EXAMPLE 1: Bright annealing 304 stainless steel

1. Select Metal.

Looking at the Ellingham diagram. The element in stainless steel with the most negative position on the diagram is chromium. Check this against the Critical Alloying Element chart in Figure 4 which confirms chromium as the metal of interest. Enter Cr in the Metal (Met) parameter of the Probe List.

2. For bright annealing, the atmosphere must be reducing to the 304 stainless. Set the Process variable to a positive NUMBER.

EXAMPLE 2: Copper brazing low carbon steel

1. Select Metal.

Refer to the Ellingham diagram. Iron has the most negative position on the diagram for this application. Check this against the Critical Alloying Element chart in Figure 4 which confirms iron as the metal of interest. Enter Fe in the Metal (Met) parameter of the Probe List.

2. For brazing, the atmosphere must be reducing to keep the metals from oxidizing, but an excessively reducing atmosphere will cause the copper braze to run out of the joint. Set the Process variable to a positive NUMBER. Record the setting and the process results, adjusting the settings until a high quality joint is achieved. Record this information.

EXAMPLE 3: Sintering of Brass Powdered Metal parts

1. Select Metal.

Refer to the Ellingham diagram. Although zinc is more highly negative than the copper, copper is typically the critical element for heat treatment of brasses. Enter Cu in the Metal (Met) parameter of the Probe List. If problems are experienced with preferential oxidation of the zinc, switch to Zn as the critical element.

2. An oxidizing atmosphere is desired. Set the Process variable to a negative NUMBER. Record the setting and the process results, adjusting the settings until the desired thickness of oxide is obtained. Record this information.

MARATHON SENSORS INC.

EXAMPLE 4: Controlled oxidation of steel

1. Select Metal.

Refer to the Ellingham diagram. For this application a light high temperature oxidation (Fe_3O_4) is desired, so we select iron as the critical element. Enter Fe in the Metal (Met) parameter of the Probe List.

2. An oxidizing atmosphere is desired. Set the Process variable to a negative NUMBER. Record the setting and the process results, adjusting the settings until the desired thickness of oxide is obtained. Record this information.

MARATHON SENSORS INC.

CALIBRATION .

The MULTIPRO instrument is shipped completely pre-calibrated. The drift characteristics of the input circuits are excellent but from time to time adjustment may be necessary to maintain a high degree of accuracy.

ANALOG INPUT CALIBRATION.

There are three analog inputs and a cold junction compensation sensor on the MULTIPRO. The input level and input features for each input are determined by changeable daughter boards that are mounted piggy back on the analog input board. There are several types of input daughter boards: thermocouple input, auxiliary input, 4 to 20 mA input, 0 to 10 V linear, RTD, and slide wire input.

The standard factory configuration is for input A to be a thermocouple input, input B to be an Oxygen probe input (auxiliary input) board, and input C to be another thermocouple input. If the instrument to be calibrated does not have the standard factory configuration, then identifying the configuration is necessary so that the proper procedure for each input board can be followed. For daughter board types see the SETUP & CONFIGURATION section.

PREPARING FOR CALIBRATION

Before placing the MULTIPRO into calibration mode, check to be sure that for each input:

- The proper thermocouple type has been selected, and
- Cold Junction compensation has been selected, if required.

The MULTIPRO should be operating for at least 30 minutes before calibration to ensure that input circuits have stabilized.

For each input of the MULTIPRO, follow the calibration procedure by the type of input board installed for that input. Once an input has been calibrated, be sure to select SAVE to ensure that the latest calibration factors are stored.

MARATHON SENSORS INC.

CALIBRATION OF THE THERMOCOUPLE BOARD

This calibration procedure assumes that a thermocouple has been selected and internal cold junction compensation is being used. If this is not true, follow the procedure for the auxiliary board using a 0 to 40 millivolt signal. The calibration procedure is as follows:

CALIBRATION PROCEDURE

1. Connect a thermocouple simulator to TB-D terminal 1 and 2 using the proper type of thermocouple wire.
2. Select the CALIBRATION page from the Full Menu.
3. Set the CALBR MODE to ZERO.
4. Set the simulator to the zero value shown in the table for the thermocouple type selected.
5. Use the knob to select Input A and press Enter.
6. Use the knob to adjust the Input A reading to equal the simulator output.
7. Press Enter to save the value.
8. Set the simulator to the span value shown in the table for the thermocouple type selected.
9. Set the CALBR MODE to SPAN.
10. Use the knob to select Input A and press Enter.
11. Use the knob to adjust the Input A reading to equal the simulator output.
12. Press Enter to save the value.
13. Repeat steps 3 through 12 until no additional change is needed.
14. Set the CALBR MODE to SAVE (The data will be saved and then the CALBR MODE will return to OFF).
15. Select another input to calibrate or exit from the calibration page.

MARATHON SENSORS INC.

Thermocouple type	Zero °F(°C)	Span°F (°C)
B	200 (90)	3000 (1800)
C	32 (0)	3000 (1800)
E	32 (0)	1300 (900)
J	32 (0)	1300 (900)
K	32 (0)	2300 (1200)
N	32 (0)	2300 (1200)
NNM	32 (0)	2000 (1100)
R	300 (150)	3000 (1800)
S	300 (150)	3000 (1800)
T	32 (0)	700 (350)

The usable ranges of the thermocouple types are shown in the table above. If having a high accuracy over a specific operating range is desirable then the input should be calibrated over that range. Follow the calibration procedure for normal calibration with the following changes. Use the low end of the desired range as the zero value and the high end as the span value. There will be more interaction between zero and span with this method. The desired operating range must fit with the limits of the table.

MARATHON SENSORS INC.

O2 AUXILIARY INPUT DAUGHTER BOARD CALIBRATION

PARTS REQUIRED

1. 1 – 0-2volt dc power supply. (for input voltage simulation)
2. 1 – set of twisted pair copper wire. (for input voltage simulation)
3. 1 – jumper (to short out the input)
4. 1 – digital volt meter. (to determine the amount of input voltage)

SETUP FOR CALIBRATION

note: for simplicity the following procedure will be referring to input B, this may not apply to all instrument configuration. (please substitute the appropriate input for this procedure)

1. determine which inputs are auxiliary inputs, the part number should let you know. (example a FDM121-4.0 has an auxiliary input on input B)
2. set the input type to linear for the board(s).

CALIBRATION PROCEDURE

1. Place a jumper from TB-D terminal 4 to terminal 5 (shorting input B).
2. Select the CALIBRATION page from the Full Menu.
3. Set the CALBR MODE to ZERO.
4. Use the knob to select Input B and press Enter.
5. Use the knob to adjust the Input B reading to 0000.
6. Press Enter to save the value.
7. Remove the jumper and connect the twisted copper wire to the voltage simulator and to Input B.
8. Set the simulator to 1.500volts dc.
9. Set the CALBR MODE to SPAN.
10. Use the knob to select Input B and press Enter.
11. Use the knob to adjust the Input B reading to 1500.
12. Press Enter to save the value.
13. Repeat steps 3 through 12 until no additional change is needed.
14. Set the CALBR MODE to SAVE (The data will be saved and then the CALBR MODE will return to OFF.)
15. Select another input to calibrate or exit from the calibration page.

MARATHON SENSORS INC.

SLIDEWIRE FEEDBACK INPUT DAUGHTER BOARD CALIBRATION

PARTS REQUIRED

1. 1 – 0-2volt dc power supply. (for input voltage simulation)
2. 1 – set of twisted pair copper wire. (for input voltage simulation)
3. 1 – jumper (to short out the input)
4. 1 – digital volt meter. (to determine the amount of input voltage)

SETUP FOR CALIBRATION

note: for simplicity the following procedure will be referring to Input C, this may not apply to all instrument configuration. (please substitute the appropriate input for this procedure)

1. determine which inputs are slidewire feedback input(s), the part number should let you know. (example a FDM123-4.0 has a slidewire feedback input on Input C)
2. set the input type to linear for the board(s).

CALIBRATION PROCEDURE

1. Place a jumper from TB-D terminal 7 to terminal 8 (shorting Input C).
2. Select the CALIBRATION page from the Full Menu.
3. Set the CALBR MODE to ZERO.
4. Use the knob to select Input C and press Enter.
5. Use the knob to adjust the Input C reading to 0000.
6. Press Enter to save the value.
7. Remove the jumper and connect the twisted copper wire to the voltage simulator and to Input C.
8. Set the simulator to 1.500volts dc.
9. Set the CALBR MODE to SPAN.
10. Use the knob to select Input C and press Enter.
11. Use the knob to adjust the Input C reading to 1500.
12. Press Enter to save the value.
13. Repeat steps 3 through 12 until no additional change is needed.
14. Set the CALBR MODE to SAVE (The data will be saved and then the CALBR MODE will return to OFF.)
15. Select another Input to calibrate or exit from the calibration page.

MARATHON SENSORS INC.

0 – 10 VOLT LINEAR DC INPUT DAUGHTER BOARD CALIBRATION

PARTS REQUIRED

1. 1 – 0-10volt dc power supply. (for input voltage simulation)
2. 1 – set of twisted pair copper wire. (for input voltage simulation)
3. 1 – jumper (to short out the input)
4. 1 – digital volt meter. (to determine the amount of input voltage)

SETUP FOR CALIBRATION

note : for simplicity the following procedure will be referring to Input C, this may not apply to all instrument configuration. (please substitute the appropriate input for this procedure)

1. Determine which inputs are 0 – 10 volt dc linear input(s), the part number should let you know. (example a FDM124-4.0 has a 0 – 10 volt dc linear input on Input C).
2. Go to the full menu and select the Input Setup page.
3. Select **in c tc type** and change to **prog.**
4. Select **in c offset** and set to 0000.
5. Select **in c span** and set to 1.00.
6. Select **in c dp** and set to 2.
7. Exit the input setup page using the **esc** key.

CALIBRATION PROCEDURE

1. Place a jumper from TB-D terminal 7 to terminal 8 (shorting Input C)
2. Select the CALIBRATION page from the Full Menu.
3. Set the CALBR MODE to ZERO.
4. Use the knob to select Input C and press Enter.
5. Use the knob to adjust the Input C reading to 0000.
6. Press Enter to save the value.
7. Remove the jumper and connect the twisted copper wire to the voltage simulator and to Input C.
8. Set the simulator to 10.00volts dc.
9. Set the CALBR MODE to SPAN.
10. Use the knob to select Input C and press Enter.
11. Use the knob to adjust the Input C reading to 10.00.
12. Press Enter to save the value.
13. Repeat steps 3 through 12 until no additional change is needed.
14. Set the CALBR MODE to SAVE (The data will be saved and then the CALBR MODE will return to OFF.)
15. Select another input to calibrate or exit from the calibration page.

MARATHON SENSORS INC.

4 – 20 MILIAMP DC INPUT DAUGHTER BOARD CALIBRATION

PARTS REQUIRED

1. 1 – 4-20 miliamp dc power supply. (for input current simulation)
2. 1 – set of twisted pair copper wire. (for input current simulation)
3. 1 – digital volt meter. (to determine the amount of input current)

SETUP FOR CALIBRATION

note : for simplicity the following procedure will be referring to Input C, this may not apply to all instrument configuration. (please substitute the appropriate input for this procedure)

1. determine which inputs are 4-20 miliamp dc input(s), the part number should let you know. (example a FDM125-4.0 has a 4-20 miliamp dc input on Input C)
2. set the input type to linear for the boards(s).

CALIBRATION PROCEDURE

1. Connect the twisted copper wire to the current simulator and to TB-D terminal 7 and terminal 8.
2. Select the CALIBRATION page from the Full Menu.
3. Set the CALBR MODE to ZERO.
4. Set the simulator to 4.0 miliamps dc.
5. Use the knob to select Input C and press Enter.
6. Use the knob to adjust the Input C reading to 0000.
7. Press Enter to save the value.
8. Set the simulator to 20.0 miliamps dc.
9. Set the CALBR MODE to SPAN.
10. Use the knob to select Input C and press Enter.
11. Use the knob to adjust the Input C reading to 2000.
12. Press Enter to save the value.
13. Repeat steps 3 through 12 until no additional change is needed.
14. Set the CALBR MODE to SAVE (The data will be saved and then the CALBR MODE will return to OFF.)
15. Select another input to calibrate or exit from the calibration page.

MARATHON SENSORS INC.

RTD DC INPUT DAUGHTER BOARD CALIBRATION

PARTS REQUIRED

1. 1 – RTD simulator. (for input simulation)
2. 1 – set of twisted copper wire, 3 conductor. (for input simulation)

SETUP FOR CALIBRATION

note : for simplicity the following procedure will be referring to Input A, this may not apply to all instrument configuration. (please substitute the appropriate input for this procedure)

CALIBRATION PROCEDURE

1. Connect the twisted copper wire 3 conductor cable to the RTD simulator TB-D terminal 1, terminal 2 and terminal 3.
2. Select the CALIBRATION page from the Full Menu.
3. Set the CALBR MODE to ZERO.
4. Set the simulator to -100 degrees.
5. Use the knob to select Input A and press Enter.
6. Use the knob to adjust the Input A reading to -100.
7. Press Enter to save the value.
8. Set the simulator to 100 degrees.
9. Set the CALBR MODE to SPAN.
10. Use the knob to select Input A and press Enter.
11. Use the knob to adjust the Input A reading to 100.
12. Press Enter to save the value.
13. Repeat steps 3 through 12 until no additional change is needed.
14. Set the CALBR MODE to SAVE. (The data will be saved and then the CALBR MODE will return to OFF.)
15. Select another input to calibrate or exit from the calibration page.

MARATHON SENSORS INC.

O2 FOR OXYGEN INPUT DAUGHTER BOARD CALIBRATION

PARTS REQUIRED

1. 1 – 0-100 millivolt dc power supply. (for input voltage simulation)
2. 1 – set of twisted pair copper wire. (for input voltage simulation)
3. 1 – jumper (to short out the input)
4. 1 – digital volt meter. (to determine the amount of input voltage)

SETUP FOR CALIBRATION

note : for simplicity the following procedure will be referring to Input B, this may not apply to all instrument configuration. (please substitute the appropriate input for this procedure.)

1. determine which inputs are auxiliary inputs, the part number should let you know. (example a FDM171-4.0 has an o2 for oxygen input on Input B.)
2. set the input type to linear for the board(s).

CALIBRATION PROCEDURE

1. Place a jumper from TB-D terminal 4 to terminal 5 (shorting Input B).
2. Select the CALIBRATION page from the Full Menu.
3. Set the CALBR MODE to ZERO.
4. Use the knob to select Input B and press Enter.
5. Use the knob to adjust the Input B reading to 0000.
6. Press Enter to save the value.
7. Remove the jumper and connect the twisted copper wire to the voltage simulator and to Input B.
8. Set the simulator to 100 milivolts dc
9. Set the CALBR MODE to SPAN.
10. Use the knob to select Input B and press Enter.
11. Use the knob to adjust the Input B reading to 100.
12. Press Enter to save the value.
13. Repeat steps 3 through 12 until no additional change is needed.
14. Set the CALBR MODE to SAVE (The data will be saved and then the CALBR MODE will return to OFF.)
15. Select another input to calibrate or exit from the calibration page.

MARATHON SENSORS INC.

16. ANALOG OUTPUT CALIBRATION

The two Analog Output signals can be configured for the following ranges: 0 to 5 V or 4 to 20 mA. The output mode for each of the Analog Outputs are determined by the two separate Dip switches on the ANALOG OUTPUT board. Any time the mode of operation is switched between current and voltage, the outputs must be recalibrated. The outputs do not have to be recalibrated when switching between signal types.

i.e.: if the output is calibrated for 0 to 5 volts, and it is needed to change from Process Variable to Proportional Output 1, no recalibration is necessary (5 volts will be equal to 100%).

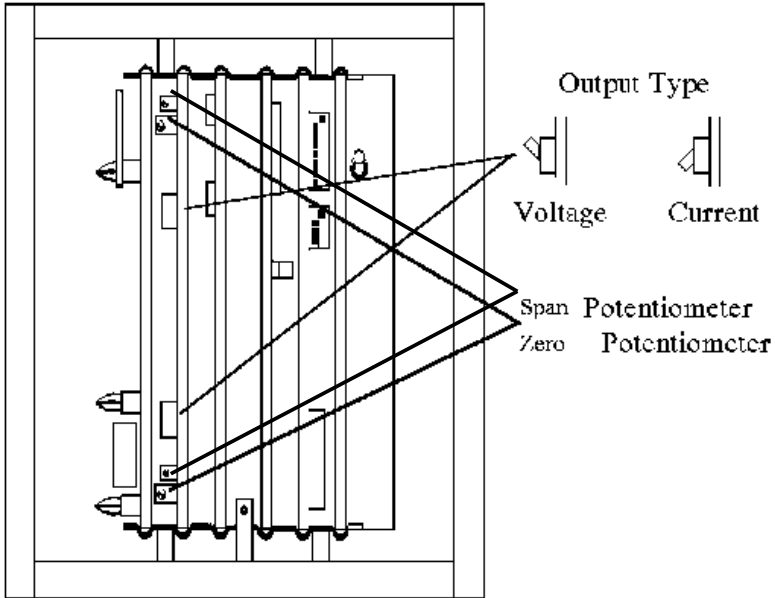

MARATHON SENSORS INC.

PREPARING FOR CALIBRATION

To set the desired mode, find the proper switch that corresponds to the output to be used. Select the voltage mode by pushing the rocker switch down at the bottom edge of the switch. Select the current mode by pushing the rocker switch down at the top of the switch. Repeat procedure for the other output.

CALIBRATING THE OUTPUTS

Consideration must be made at this time about which type output, current or voltage, is to be used. Check the two rocker switches on the Analog Output board to confirm that the desired mode is selected for each output.

NOTE

Remove the FRONT PANEL by loosening the black knurled knob in the counterclockwise direction. Remove the panel from the chassis and support it near the instrument.

To calibrate the outputs using the following method.

*Remove any wires at the Analog Output terminals (TBD-13, TBD-14, TBD-15 and TBD-16).

* Attach the leads of a digital multi-meter(DMM) to the terminals that correspond to the output to be calibrated (TBD-13(+) and TBD-14(-) for Analog Output #1. TBD-15 (+) and TBD-16(-) for Analog Output #2).

* In calibration menu set calbr mode to zero.

* Find the OFFSET POT for the output to be adjusted. Adjust the pot until the DMM reads 4 mA current output or 0 V.

Repeat * steps for the other output.

To get the full SPAN output value, set the calbr mode to span.

With the DMM connected at the proper output terminal connection, adjust the GAIN pot of the corresponding output until the DMM reads the required output (5V max) or 20 mA.

Move the meter leads to the other Analog Output and repeat the previous step for the SPAN output.

Repeat the Zero and Span process until no further adjustment is required.

Reattach any wires removed from the Analog Output terminals.

Reattach the units FRONT PANEL to the chassis. The Analog Output Calibration procedure is now complete.

Analog OPTO Tweaking

The analog OPTO tweaking feature of the Multipro allows the operator to adjust the zero and span of each module on the analog OPTO rack. This is similar to calibration except that the operation is done in the Multipro after the digital data is received from the OPTO rack. The purpose of the tweaking feature is to provide a means of fine tuning the readings from the OPTO board. For example, if a thermocouple attached to the appropriate module is reading a few degrees high or low the tweaking feature can be used to adjust for this error.

MARATHON SENSORS INC.

To use the analog OPTO tweaking feature it must be activated. This is done in the ANALOG EVENTS page. Select the ANALOG TWEAK option and change it to YES. The tweaking feature applies to all sixteen modules on the rack. Be sure that the offset is set to 0000 and the span to 1.000 on any modules you do not wish to adjust. The offset and span effect the digital data received from the OPTO rack before any linearization is applied. The range of the offset number is + or - 999 counts. The full scale range of the data from the OPTO module is 4095 counts regardless of the type of module. For example a 0 to 5 volt module full scale is 4095 counts therefore each counts is 1.22 millivolts.

The tweaking offset can therefore adjust the offset (zero) of the approximately 24%. The range of the span adjustment is 0.900 to 1.100. This allows a + or - 10% adjust to the gain. Since the span multiplier occurs on the non-linearized data, an error of 2% may need a slightly higher or lower multiplier than 2%.

The best way to use the tweaking feature is the same way a calibration would be done. First apply a zero or near zero signal, and adjust the offset for a correct reading. then apply a full scale signal and adjust the span for a correct reading. Repeat the zero and span processes until there is no interaction. For greater accuracy over a known operating range, use the low end of the range for the zero and the high end of the range for the span. The disadvantage of this technique is that there will be more interaction between the zero and the span.

The sophisticated Multipro user might be using the analog OPTO address offset feature to have more than one analog OPTO rack on the Multipro. The tweaking feature can not distinguish which board is active and would apply the tweaking factors to the data. Since the logic programmer is probably being used to switch between the boards, the logic programmer could also turn on the tweaking feature for the desired board and turn it off when selecting the other board(s). This would allow the tweaking feature to be used on a critical board without affecting the data from the other boards.

MARATHON SENSORS INC.

SPARE PARTS LIST

Marathon recommends that customer's purchase a second unit as a back up so that service remains uninterrupted. If that is not possible then at least purchase the following items:

- MFU - .25SB - 1/4 AMPERE SLOW BLOW FUSE
- A810151 - fast analog input board
- A810201 - communications board
- A810153 - Turbo CPU board
- A810179 - Smart interface board
- A810204 - Triac/relay board
- A810181 - Multipro display assembly
- A810076 - Auxiliary / O2 mV daughter board
- A810077 - Thermocouple daughter board
- A810095 - Slidewire Feedback daughter board (if used)
- A810115 - Resistive Temperature Device daughter board (if used)
- A810147 - 0 to 10 V Linear daughter board (if used)
- A810168 - 4 to 20 mA daughter board (if used)
- A810071 - analog input board

MARATHON SENSORS INC.

TABLE OF ABBREVIATIONS

Table of abbreviations	definition
ac	Alternating current
ao	analog output location also called analog outputs
C	centigrade
CV	calculated value or control variable *
dc	direct current
Dim	dimensioning statement
F	Fahrenheit
Hz	Hertz
I/O	input <u>or</u> output
mA	milliampere(s) also called milliamps
mV dc	millivolt direct current
PF	Process Factor
Rev	Revision
RTD	Resistive Temperature Device
SCSP	Supervisory Computer Software system
TB	Terminal Block
T/C	Thermocouple
V	volts
V ac	Volts alternating current
V dc	Volts direct current
v	version
#	number
"	inches

* This is situation dependant. CV is used in display space to indicate a value to be entered in a program slot.

MARATHON SENSORS INC.

Glossary Rules of form:

Anything in block capitals (ANSI, BYTE, BAUD) is an acronym or abbreviation.

Manufactured terms: Technical Jargon for which there is no satisfactory substitute term in common English as spoken in the United States of America.

The definitions provided here are those in common usage at Marathon Sensors. While some may be industry standard others are specialized to Marathon usage.

Glossary:

ANSI (acronym): American National Standard Institute. Organization for setting standards of performance, hardness, safety or other measurable feature. Their standards are used in laws and codes for product safety and reliability.

ASCII (acronym): American Standard Code for Information Interchange. Its use here usually refers to the standard code for serial communications of alphanumeric and control characters.

Asynchronous a communication method where data is sent when it is ready without reference to a timing clock or waiting until the receiver signals it is ready to receive it.

BASIC (n): Beginners All-purpose Symbolic Instruction Code. A programming language developed at Dartmouth College as a learning tool.

BAUD rate (n): standard information exchange speeds that are used by telephone data exchange equipment (modem, fax = facsimile, two-way video conferencing and the like) equal to number of signal events or BITS per second used.

Binary (n): The basic coding system of all computer languages consisting of 1's and 0's indicating either an off or on position for a switch.

BIT (n): a single minute piece of binary data represented by either a 1 or a 0. A 1 = on, a 0 = off. These on or off positions are grouped into a block of 8 BITS to make up the basic building blocks of data processing memory storage and retrieval.

Block diagram (n): a shortened, graphical representation of the cause and effect relationship between the input and output of the physical system.

Block mapping (g): a method of moving and retrieving stored data that resides

MARATHON SENSORS INC.

in specific memory locations called blocks.

BYTE (N): an eight BIT piece of memory storage and retrieval data.

Buss (n): parallel lines for transfer signals between devices or components.

Character (n): a letter, digit, or other symbol used as a representation of data.

String (n): a connected sequence of characters.

Control (n): a character whose appearance in a particular context starts, stops, or modifies an operation that effects the recording, transmission, interpretation or processing of data.

Closed loop (n): a control system in which the control action is dependant on the output in some way.

Control loop (n): The continuous comparison of a process output to its setpoint ; adjusting the inputs to the process to achieve and maintain that setpoint.

Controlled output (n): The quantity or condition of the item which is controlled.

Controller (n): A device with a transfer function especially tailored to improve the dynamics of a system. In practice, it is a mechanism, with adjustable parameters, designed to receive a setpoint and feedback signals and to send an output signal to activate a final control element such as a valve.

Control system (n): an arrangement of Physical components organized in a way that allows it to command, direct, regulate itself or another system.

Control signal(n): the quantity or condition which is applied to the item being controlled.

Datalogging (v): recording of historical data about a furnace operation on a computer; to record process parameters.

Decimal (n): base ten number system using the characters 0 through 9 to represent values.

Derivative (n): A function within the a P. I. D. controller which produces an output proportional to the rate of change of the input variable.

Digital Control System (n): a system in which the components are discrete time devices and are exposed to pulsed rather than continuous signals.

MARATHON SENSORS INC.

DIP switch (acronym) "dual inline package" switch: pre formed micro switch packets which allow the operator to "permanently" preset a single programmable item such as the address of an instrument in a daisy chain. DIP switches produce a rudimentary binary message dependant upon the wiring formation and if they are "read" by some computer based communications system.

DIN (acronym): an abbreviation for the German national standards organization, sets exacting standards for industrial openings in cabinet faces, camera lenses, etc. Also sets sizes for laboratory glassware, film speeds. used here in relation to size of opening standard.

Disturbance (n): an undesired input signal which affects the value of the controlled output. If this is an electronic signal it is also referred to as "Noise".

DPR = digital process recorder: Honeywell™ trademarked name portion as in DPR100, DPR3000 for a chart recorder. These recorders range from single pen strip recorders to multipen circular ones.

Error (n) : the difference between the setpoint of a controller and its measured variable

Event (n): a binary input or output bit(of data) usually switch or contact data.
Event mapping (g): the ability of a programmer to place a bit of information in a specific location where it can then be retrieved by a program for use.

Feedback (n): the property of a closed loop system which permits a control variable to be compared with the input so that the appropriate control action may be formed as a function of the output and input.

Filter (n): a transducer whose frequency response characteristics are chosen so that signals within a certain frequency range are faithfully transmitted with little of other frequencies passing through.

Frequency (n): the number of complete cycles per unit of time that a sinusoidal (or any regular) oscillation occurs.

Gain (n): a number which represents the ratio of the output device to its input.

Gap (n): the space in the flow of processing between groups of parts. In most

MARATHON SENSORS INC.

recipes gaps are expressed as time measurements.

Half duplex (n): a one way at a time data communication; both devices can send and receive data only one at a time.

Handshake (n): An interface procedure that is based on status/data signals; that assures an orderly data transfer as opposed to an asynchronous exchange.

Hertz (n): An electrical term; a unit of frequency equal to one cycle per second.

Hexadecimal (n): A base sixteen number system using the characters 0 through 9 and A through F to represent the values. Often abbreviated as HEX.

Host (n): the primary or controlling instrument in a multipart system.

Hysteresis (n): The difference in output when a setpoint is first approached with increasing and then decreasing value. Expressed in terms of percent full scale during any one calibration cycle, similar to back-lash in a gear train cycle.

Input (n): a signal or other excitation applied to a control system from an external source to produce a specific response from the control system.

Integral (adj): the I in P. I. D. control, a function which produces an output which is proportional to the integral of the error signal. When the error is zero the integral is a constant; when the error is a constant, the integral is a ramp function.

Interface (n): the means by which two systems or devices are connected and communicate with each other.

Interpreter (n): a system program that converts and executes each instruction of a high level language program into machine code as it runs before going on to the next instruction.

Interrupt (n): a program device which stops a process or program in such a way that it can be resumed.

Load tracking (n): the record of a group of parts through the processing set for them.

Leading edge (n): the first part of group of parts going through processing.

MARATHON SENSORS INC.

LED = light emitting diode (n) : abbreviation for a diode functioning as a lamp usually in a digital data display.

Linearize (a verb manufactured from a noun): with a particular, limited range of variables; substitution of a linear function for a non linear one. This linear function gives approximately the same relationships.

Loop (n) a closed path in a feedback control system.

Manipulated variable (n) the process variable that is changed by the controller in order to effect corrections, the control signal.

Measured variable (n): the process parameter which is being controlled.

Menuing (manufactured verb from the noun menu) options (g) a term adopted by Marathon engineers to name the process of reading menu selections from the screen of a Multipro™ or other Marathon instrument with that option in its program.

Noise(n): electronic interference that conceals or causes unwanted fluctuations in the variable or the signal it is supposed to represent. See also Disturbance.

Nominal part density (n) : a predetermined or premeasured quantity of parts concentrated on a given location of a belt in a belt furnace.

Octal (n): a base eight number system using the characters 0 through 7 to represent values.

Offset (n): the steady state error in a control loop stemming from proportional only control action.

ON/OFF control, also called binary or logic control (n) : the control system in which the final control device has only two possible positions or states.

Open loop system: one in which the control is independent of the output.

Operator Interface: (n) the point at which human beings and system instruments connect. This can be a faceplate keyboard, a computer touch screen, or a computer keyboard and monitor. Other "interfaces" include switches, controlling leavers, Non system faceplates, buttons, monitors and keyboards.

Output: the actual response from the control system.

MARATHON SENSORS INC.

Overshoot: the difference between the final steady state value and the value of the first reading. Often expressed as a fraction of the difference between the initial and final values.

Parameter: Marathon Sensors uses the term to define a value that occupies a 16 bit binary word. This can consist of signed or unsigned values and the location can be used for one or more values depending on the size of the code required to store the value.

Parameter table: a group of 240 of these data.

PI (acronym) : the Marathon Sensors Inc. version of the predefined constant .

PLC (abbreviation) = programmable logic controller: a sophisticated piece of equipment capable of communicating with a programming unit--(Multipro, Process Master, 10PULSE) and equipment --(solenoid valves, drive belts) with the ability to get work done by the equipment that the programming unit calls for, such as, increasing gas flow to the furnace, moving parts through the furnace, or opening or closing the furnace door. A PLC can store programs and do its own programs as well as those of the control unit. It's response time is shorter than most programming units when relating to switches and controls of the solenoid type.

Proportional (adj): the P in P. I. D.; in a PID controller, the function which produces an output in proportion to the error signal.

Realrun* screens (n) a display on a computer monitor usually the Process Master file server computer monitor or a node (OVERVIEW 8600) at an operator work station. These screens are used to show current Data in the master Multipro* in organized, easy to see format. Realrun* can be used to display limited amounts of computer Data information such as an in process part or job number.

Recipe, (n) a sequential list of setpoints, event action and soak times to be used for every control loop in a system. Setpoints for every control loop in the line of a Beltpro* system.

Reference input (n) :an external signal applied to a feedback control system in order to command a specified action; often representative of ideal behavior.

Regulator (n) : a controller with the primary objective of maintaining an output constant in spite of load variations.

MARATHON SENSORS INC.

Setpoint (n): The desired value of a measured variable ; the controller acts to make the measured variable match the setpoint.

Settling time (n) : amount of time required to reach 2 to 5 % of the final value.

Stable (n): a state of being, a system that will stay at rest unless excited by an external source and will return to rest in external excitements are removed.

Three mode controller (n) : a P. I. D. controller.

Time constant (n) : the time needed for the output to change from a given value to within 63% of the total change when a step input is made. This is represented by the Greek letter tau or t in formulas.

Toggle (v) from the noun toggle switch: to move between two preset states -- "to toggle between off and on" for example.

Trailing edge (n) the last of a group of parts going through processing.

Transducer (n) a device which converts one energy form into another.

UDC (abbreviation) = universal digital controller: Honeywell™ trademarked temperature control devices as in UDC2000, UDC3000 etc.

WORD(n): a two BYTE piece of binary memory storage and retrieval data.

MARATHON SENSORS INC.

We would like to hear from you. Please drop us a note on the Internet at

WWW.MARATHONMONITORS.COM

All available manuals are located on the net using Adobe Acrobat.