

**Marathon Sensors Inc.**  
**AACC 2000 Carbon Controller**  
**Operator's Guide**



***Marathon  
Sensors Inc.***

COPYRIGHT © 1999  
MARATHON SENSORS INC.

# Marathon Sensors Inc.

---

Part # F200054

COPYRIGHT © 1999

MARATHON SENSORS INC.

3100 East Kemper Road, Cincinnati, Ohio 45241

1-800-547-1055, PHONE: (513) 772-1000, FAX: (513) 326-7090

No part of this document may be stored or reproduced by any means whatsoever without prior written permission of Marathon Sensors Inc.

All trademarks used in this publication are duly marked and the sole property of their respective owners. No attempt at trademark or copyright infringement is intended or implied.

Marathon Sensors makes no warranties express or implied beyond the written warranty presented at initial purchase. Marathon Sensors Inc. is not responsible for any product, process, damage or injury incurred while using this equipment. Marathon Sensors makes no representations or warranties with respect to the contents hereof and specifically disclaims any warranties of merchantability or fitness for any particular application or purpose.

# Marathon Sensors Inc.

---

## Table of Contents

Introduction.....	3
Features .....	3
Wiring.....	4
Operation .....	6
Key Description.....	6
Auto/Man.....	6
Setpoint .....	6
Probe Care.....	6
Communications Address .....	7
Alarm Setpoints .....	7
Alarm Display .....	7
Alarm Acknowledge .....	7
Instrument Configuration .....	8
Temperature Units.....	8
Thermocouple Type.....	9
Communications.....	9
Analog Output .....	9
Analog Output 2 .....	10
Other Parameters.....	10
Factory Parameter Setups.....	11

# **AACC 2000 Preferred Carbon Controller F911577-DAAC**

## **INTRODUCTION**

The purpose of this document is to provide a quick reference guide for the AACC 2000 preferred. The preferred version is configured for the most common applications of the carbon controller. This document explains the simple steps needed to wire and operate the controller. Also the most common configuration changes are explained.

## **FEATURES**

The AACC 2000 preferred is pre-configured with two control contacts for gas and air solenoids and a 4 to 20 ma analog output for gas control.

A 4-20 ma analog output for retransmission of 0 to 2% carbon.

Three alarm contacts are pre-configured for carbon deviation (+/- .1%), 1400 deg F minimum temperature, and sensor break/probe fault. The contacts are normally closed when there is no alarm condition.

Probe maintenance features are preset for typical applications.

The RS-485 port is preset for MSI communications at 1200 baud.

# Marathon Sensors Inc.

---

## WIRING

Refer to the main AACC 2000 manual for EMC and safety requirements when wiring to the instrument. Figure 1 shows the terminal assignments as setup by the factory.

Connect the probe thermocouple to the V+ and V- terminals using the proper extension wire. The thermocouple type preset for the AACC 2000 is type S.

Connect the probe millivolts to terminals 6C (+) and 6B (-). Do not remove the wires that are already on the instrument for the probe impedance test. These wires connect terminals 5D to 6C, terminals 6D to JE, and terminals 5C to JD.

Wire the alarm contacts as desired.

Connect the control outputs for the appropriate devices.

Connect the 4 - 20 ma % carbon retransmission signal from terminals 3A (+) and 3B (-) to the recording device.

Connect the burn-off contact to the burn-off solenoid.

Connect AC power, 100 -240 VAC, to the live, neutral and ground terminals.

# Marathon Sensors Inc.

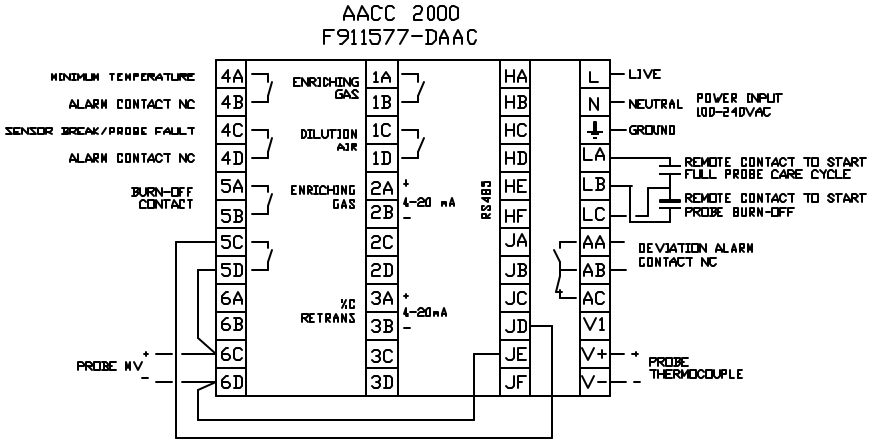

**Figure 1 Signal Assignments**

## OPERATION

### KEY DESCRIPTION

The four rectangular buttons at the bottom of the instrument are used to view or enter data into the instrument. The left most button with a picture of a sheet of paper with the corner bent over is the page key. The next button with the circular arrow is the scroll key. The third button with a triangle pointing down is the down arrow key. The fourth or right most button with the triangle pointing up is the up arrow key.

There are two small round buttons just above the rectangular buttons. The left one is the auto/man button and the right one is the probe care button.

### AUTO/MAN

To switch the controller from automatic (auto) to manual (man) or manual to automatic, press the auto/man button until the appropriate beacon is lit.

### SETPOINT

When the controller is in auto mode the setpoint can be changed by depressing the up or down arrow keys until the lower display shows the desired value.

### PROBE CARE

A probe care cycle can be started by pressing the run/hold button. This will run a probe impedance test followed by a probe burn-off. To start just an impedance test or just a burn-off, press the page key until the Care List is displayed, then

# Marathon Sensors Inc.

---

press the scroll key once. Then use the arrow keys to select imp for impedance test or burn for burn-off.

## **COMMUNICATIONS ADDRESS**

The AACC 2000 is preset for MSI communications at 1200 baud. To set the instrument address, press the page key until CMS List is displayed. Press the scroll key once and then use the arrow keys to set the desired address.

## **ALARM SETPOINTS**

Alarm setpoints can be changed from the alarm list. Press the page key several times until AL List is displayed. Press the scroll key until 1dEv or 3FL.1 is displayed. The 1dEv is the process deviation alarm setpoint and the 3FL.1 is the minimum temperature alarm setpoint. The setpoints are changed by using the arrow keys.

## **ALARM DISPLAY**

A sensor break alarm is displayed by a flashing S.br in the upper display. This indicates that the probe thermocouple connection is open. The process deviation alarm (1dEv), minimum temperature alarm (3FL.1), and probe fault (PFLt) alarms show up flashing in the lower display.

## **ALARM ACKNOWLEDGE**

The sensor break, process deviation alarm (1dEv), and the minimum temperature alarm (3FL.1) can not be acknowledged. They will clear by themselves when the alarm condition goes away. The probe fault, PFLt, alarm is acknowledged by pressing the page and scroll keys together.

# Marathon Sensors Inc.

---

## INSTRUMENT CONFIGURATION

Configuration mode is used to change items that are usually set once for a specific application. When the instrument is in configuration mode, all contacts open and the analog outputs go to zero.

To enter configuration mode, press the page key several times until ACCS List appears. Press the scroll key once and then use the arrow keys to set the level 1 (access) password. Press the scroll key once and then use the arrow keys to select conf. Press the scroll key once and then use the arrow keys to enter the level 2 (conf) password. Press the scroll key once and the instrument is now in configuration mode.

To exit configuration mode, press the page key several times until exit appears in the upper display. Press the up arrow key once to show yes in the lower display. The instrument will reset, perform its power up sequence, and then enter the normal operating mode.

The items below will give a list name (i.e. inst ConF) and a header for the parameter to be changed. To change the parameter, enter configuration and then press the page key until the list name is displayed. Press the scroll key until the upper display shows the parameter header. Use the arrow keys to select the desired parameter value. When finished, either exit configuration mode or continue to another parameter.

### TEMPERATURE UNITS

The temperature unit are under the PV ConF list as parameter unit. Choices are deg C, deg F, deg K or none.

# Marathon Sensors Inc.

---

## **THERMOCOUPLE TYPE**

The thermocouple type is under the iP Conf list as parameter inPt. There are many choices but the most common would be S.tc, r.tc, k.tc, or b.tc for type S, R, K, or B thermocouples respectively.

## **COMMUNICATIONS**

Communications setups are under the HA ConF list. The most common parameter to change is the bAud parameter which sets the communications baud rate. Choices are 1200, 2400, 4800, 9600, and 19.20 (k). To select Modbus communications mode, change the Func parameter to mod, the prty parameter to none, the rES parameter to FuLL, and dELY to yes. For Marathon Sensors block mode set the Func parameter to mAr, the prty parameter to EvEn, and dELY to no.

## **ANALOG OUTPUT 1**

Setup parameters for analog output 1 are under the 2A ConF list. The standard setups are the Func parameter is OP.1, the VAL.L parameter is 0, the VAL.H parameter is 100, the unit parameter is mA, the Out.L parameter is 4.0, and the Out.H parameter is 20.0. Therefore, the output provides a 4-20 ma signal for controlling enriching gas. To change the output for dilution air, then set the Func parameter to OP.2. To use the analog output to handle both dilution air and enriching gas, set the Func parameter to OP and the VAL.L to -100. The output would then produce 4 ma when full (100%) dilution air is requested and 20 ma when full (100%) enriching gas is requested. This analog output could also be used to retransmit temperature (IP.1) or millivolts (IP.2).

## **ANALOG OUTPUT 2**

Setup parameters for analog output 2 are under the 3A ConF list. The standard setups are the Func parameter is PV, the VAL.L parameter is 0, the VAL.H parameter is 2, the unit parameter is mA, the Out.L parameter is 4.0, and the Out.H parameter is 20.0. This analog output could also be used to retransmit temperature (IP.1) or millivolts (IP.2).

## **OTHER PARAMETERS**

Other configuration parameters can be changed in a similar manner. Please refer to the configuration section in the main manual for all the options.

# Marathon Sensors Inc.

---

## FACTORY PARAMETER SETUPS

\* = instrument set the value

### Home list

Process Variable		*
Target Setpoint		0
Auto/Manual Mode	M- a	man
Output power	OP	*
Reference Number	rEF	0

### Probe List

Process Factor	PF	150
Milivolt Offset	OFFS	0
H-CO Compensation	H- CO	20
Probe Temperature	Ptc	*
Probe Millivolts	Pmv	*
Auxilliary Input	Axi n	* (hide)

### Care List

Care	CArE	OFF
Measured Recovery Time	prt.r	*
Temperature Minimum	tmi n	OFF
Probe Test Interval	Pti	OFF
Maximum Impedance	i mPH	20
Probe Test Recovery Time	Ptr t	30
Burn Off Time	bot	60
Burn Off Recovery Time	bort	30
Final Delay	FdE	5
Impedence Result	I mp.r	*

### User List

		Hide
Number 1	n1	0
Number 2	n2	0
Number 3	n3	0
Number 4	n4	0

# Marathon Sensors Inc.

---

Number 5	n5	0
Number 6	n6	0
Number 7	n7	0
Number 8	n8	0
Number 9	n9	0
Number 10	n10	0
Number 11	n11	0
Number 12	n12	0
Number 13	n13	0
Number 14	n14	0
Number 15	n15	0

## Alarm List

Alarm 1 Setpoint	1---	0.1
Alarm 3 Setpoint	3---	1400
Alarm 1 Hysteresis	HY1	1 (hide)
Alarm 2 Hysteresis	HY2	na (hide)
Alarm 3 Hysteresis	HY3	1 (hide)
Alarm 4 Hysteresis	HY4	na (hide)
Loop Break Time	Lbt	OFF (hide)
Enable Diagnostic Messages	di AG	NO (hide)

## Autotune List

		Hide
Autotune Enable	tunE	OFF
Automatic manual Reset Calculation	Adc	MAN

## PID List

Current PID Set	Set	Pid.1
Proportional Band PID1	Pb	1
Integral Time PID1	ti	OFF
Derivative Time PID1	td	OFF
Manual Reset	rES	0
Cutback High	Hcb	Auto (hide)

# Marathon Sensors Inc.

---

Cutback Low PID1	Lcb	Auto (hide)
Relative cool gain set 1	rELC	1 (hide)
Proportional Band PID2	Pb2	1
Integral Time PID2	ti 2	OFF
Derivative Time PID2	td2	OFF
Manual Reset PID2	rES2	0
Cutback High PID2	Hcb2	Auto (hide)
Cutback Low PID2	Lcb2	Auto (hide)
Relative cool gain set 2	rEL.2	1 (hide)

## Setpoint List

Setpoint Select	SSEL	SP 1
Setpoint 1	SP1	0
Setpoint 2	Sp2	0
Setpoint Low Limit	SPL	0 (hide)
Setpoint High Limit	SPH	2 (hide)
Setpoint 2 Low Limit	SP2.L	0 (hide)
Setpoint 2 High Limit	SP2.H	2 (hide)
Setpoint Rate Limit	Sprr	OFF (hide)
Holdback Type	Hb.tY	OFF (hide)

## Input List

		Hide
Filter 1	Fi Lt	OFF
Filter 3	FLT3	OFF
Simple offset 1	OFS.1	0
ADC millivolts 1	mv.1	*
ADC millivolts 2	mv.2	*
CJC Temperature	CJC.1	*
IP1 linearized value	Li .1	*
IP3 linearized value	Li .3	*
Current input used for pv	PV.SL	*

## Output List

		Hide
Low Power Limit	OP.Lo	-100

## Marathon Sensors Inc.

---

High Power Limit	OP.Hi	100
Output Rate Limit	Oprr	OFF
Cycle time OP1	CYC.1	10
OP1 Minimum On Time	ont.1	Auto
Cycle time OP2	CYC.2	10
OP2 Minimum On time	ont.2	Auto
Deadband	db	OFF
Sensor Break Output Power	Sb.OP	0

### Comms List

Comms Address	Addr	1
---------------	------	---

### Info List

Hide

### Inst Conf

Function: O2, %C, Dewpoint, Redox	Zr.Fn	Carb
Control Type	Ctrl	Pid
Instrument type: Monitor/Controller	tYPE	Ctrl
Control Action	Act	REV
Type of cooling	COOL	lin
Control Time Units	ti.td	Sec
dtYP	dtYP	PV
Manual Key Enable	m-A	EnAb
Run hold button	r-h	EnAb
Power feedback	PwrF	OFF
Feedforward Type	Fwd.t	nonE
Sensor Break Action	Sbr.t	Sb.OP
Forced manual output	FOP	no
BCD Input Function	bcd	nonE
Gain Scheduling	Gsch	no

# Marathon Sensors Inc.

---

## PV Conf

Instrument Units	uni t	F
Display Resolution	dEc.P	nn.nn
Range low	rnG.L	0
Range High	rnG.H	2

## IP Conf

Linearisation type	i nPt	S.tc
CJC Type	CJC	Auto
Sensor break Impedance	i mP	Auto

## SP Conf

Number of Setpoints	nSP	2
Remote Tracking Configuration	rm.tr	OFF
manual track Configuration	m.tr	OFF
SRL rate units	rmP.U	PSEC
Remote Setpoint Configuration	rmt	nonE

## Alarm Conf

Alarm 1 Type	AL1	dEv
Alarm 1 Latch	Ltch	NO
Alarm 1 Block	bLoc	NO
Alarm 2 Type	AL2	OFF
Alarm 2 Latch	Ltch	NO
Alarm 2 Block	bLoc	NO
Alarm 3 Type	AL3	FL.1
Alarm 3 Latch	Ltch	NO
Alarm 3 Block	bLoc	NO
Alarm 4 Type	AL4	OFF
Alarm 4 Latch	Ltch	NO
Alarm 4 Block	bLoc	NO

# Marathon Sensors Inc.

---

## LA Conf

Logic Input A Ident	i d	LoG.I
Logic Input A Slot Function	Func	CARe

## LB Conf

Logic Input B Ident	i d	LoG.I
Logic Input B Slot Function	Func	burn

## AA Conf

Fixed Module AA Ident	i d	rELy
Fixed Module AA Slot Function	Func	dIG
Summary OP AA invert	Sens	inv
Summary OP AA Conf		1dEv

## Module

### HA Conf

Interface Module H Ident	i d	cmS
Interface Module H Slot Function	Func	mAr
Baud Rate	bAud	1200
Comms Parity	Pr ty	EvEn
Comms Delay	dELY	no

## Module JA Conf

Logic Input B Ident	i d	nonE
Logic Input B Slot Function	Func	nonE

## Module 1A Conf

Module 1A Ident	i d	rELy
-----------------	-----	------

# Marathon Sensors Inc.

---

Module 1A Slot Function	Func	OP.1
Module 1A Low Value	VAL.L	0
Module 1A High Value	VAL.H	100
Module 1A Low Output Range	Out.L	0
Module 1A High Output Range	Out.H	100

## Module 1C Conf

Module 1C Ident	i d	rELy
Module 1C Slot Function	Func	OP.2
Module 1C Low Value	VAL.L	0
Module 1C High Value	VAL.H	100
Module 1C Low Output Range	Out.L	0
Module 1C High Output Range	Out.H	100

## Module 2A Conf

Module 2A Ident	i d	dc.rE
Module 2A Slot Function	Func	OP.1
Module 2A Low Value	VAL.L	0
Module 2A High Value	VAL.H	100
Output 2A units	uni t	mA
Module 2A Low Output Range	Out.L	4
Module 2A High Output Range	Out.H	20

## Module 3A Conf

Module 3A Ident	i d	dc.rE
Module 3A Slot Function	Func	PV
Module 3A Low Value	VAL.L	0

# Marathon Sensors Inc.

---

Module 3A High Value	VAL.H	2
Output 3A units	uni t	mA
Module 3A Low Output Range	Out.L	4
Module 3A High Output Range	Out.H	20

## Module 4A Conf

Module 4A Ident	i d	rELy
Module 4A Slot Function	Func	dIG
Summary OP 4A Invert	SEnS	inv
Summary OP 4A configuration		3FL.1

## Module 4C Conf

Module 4C Ident	i d	rELy
Module 4C Slot Function	Func	dIG
Summary OP 4C Invert	SEnS	inv
Summary OP 4C configuration		Sbr/PFLt/V FLt

## Module 5A Conf

Module 5A Ident	i d	rELy
Module 5A Slot Function	Func	dIG
Summary OP 5A Invert	SEnS	nor
Summary OP 5A configuration		burn/Veri

## Module 5C Conf

Module 5C Ident	i d	rELy
Module 5C Slot Function	Func	dIG
Summary OP 5C Invert	SEnS	nor

# Marathon Sensors Inc.

---

Summary OP 5C  
configuration

ImP

## Module 6A Conf

Module 6A Ident	i d	dC.iP
Module 6A Slot Function	Func	PmV
Module 6A Input Type	i nPt	Hiln
Module 6A Input Value Low	i nP.L	-0.2
Module 6A Input Value High	i nP.H	1.8
Module 6A Displayed Value Low	VAL.L	-200
Module 6A Displayed Value High	VAL.H	1800

## CAL Conf

Calibration point	rcAL	nonE
User calibration enable	VCAL	no
Low point for Input 1	Pt1.L	0
High point for Input 1	Pt1.H	0
Offset low for input 1	OF1.L	0
Offset high for input 1	OF1.H	0

## PASS Conf

Access Mode User Password	ACC.P	1
Configuration Mode User Password	cnF.P	2

# Marathon Sensors Inc.

---

## INDEX

### A

Aacc 2000 Preferred Carbon  
Controller, 3  
Alarm Acknowledge, 7  
Alarm Display, 7  
Alarm Setpoints, 7  
Analog Output 1, 9  
Analog Output 2, 10  
Auto/Man, 6

### C

Communications, 9  
Communications Address, 7

### F

Factory Parameter Setups, 11  
Features, 3

### I

Instrument Configuration, 8  
Introduction, 3

### K

Key Description, 6

### O

Operation, 6  
Other Parameters, 10

### P

Probe Care, 6

### S

Setpoint, 6

### T

Temperature Units, 8  
Thermocouple Type, 9

### W

Wiring, 4