

Lorox™ Controller

INSTALLATION & OPERATIONS MANUAL

Ver. 1.2
April 2002



***Marathon
Sensors Inc.***

3100 E. Kemper Rd.
Cincinnati, OH 45241
(513) 772-1000
www.marathonsensors.com

Marathon Sensors Inc.

Part # F200082

COPYRIGHT © 2002
MARATHON SENSORS INC.
3100 East Kemper Road, Cincinnati, Ohio 45241
1-800-547-1055
PHONE: (513) 772-1000
FAX: (513) 326-7090

No part of this document may be stored or reproduced by any means whatsoever without prior written permission of Marathon Sensors Inc.

All trademarks used in this publication are duly marked and the sole property of their respective owners. No attempt at trademark or copyright infringement is intended or implied.

Marathon Sensors makes no warranties express or implied beyond the written warranty presented at initial purchase. Marathon Sensors Inc. is not responsible for any product, process, damage or injury incurred while using this equipment. Marathon Sensors makes no representations or warranties with respect to the contents hereof and specifically disclaims any warranties of merchantability or fitness for any particular application or purpose.

Revised:

Revision 1.0 March 13, 2002
Revision 1.1 March 22, 2002
Revision 1.2 April 2, 2002

Table of Contents

INTRODUCTION..... 5

PACKAGE CONTENTS 5

INSTALLATION 5

 LOCATION 5

 ELECTRICAL CONNECTIONS..... 5

AC Power Connections..... 6

DC Signal Connections 7

Dualpro Connections..... 7

 GAS SAMPLING CONNECTIONS 7

SYSTEM OPERATION 8

 NORMAL OPERATION..... 8

Automatic Loop Control 9

Conditional Tests of the Lorox System 9

 SYSTEM ALARMS..... 10

 THE DUALPRO FRONT PANEL 11

 THE DUALPRO KEYPAD 12

Setpoint Key..... 15

Entering Loop Set Points..... 16

DISPLAY PARAMETERS 18

SETUP PARAMETERS 27

CALIBRATION PROCEDURES..... 41

 LOROX PROBE CALIBRATION 41

Manual Lorox Probe Calibration..... 41

Turning on the Events..... 43

Viewing the Probe Data 43

Entering the Offset and Span Correction Values..... 43

Automatic Lorox Probe Calibration..... 44

 DUALPRO CALIBRATION..... 45

MAINTENANCE 46

 LOROX PROBE 46

 DUALPRO..... 46

APPENDIX A – MV TO PERCENT OXYGEN CHART 47

APPENDIX B – TROUBLESHOOTING 49

 THERE IS NO MILLIVOLT OUTPUT FROM THE PROBE. 49

 HOW COME THE CALIBRATION ROUTINE DOES NOT RUN? 49

 HOW COME I CAN’T SET THE PROBE TEMPERATURE SET POINT HIGHER THAN 750°C? 49

 HOW DO I KNOW IF THE BACKGROUND PROGRAM IS RUNNING? 49

 CAN I CHANGE THE CALIBRATION TIMERS DURING A CALIBRATION?..... 50

 HOW DO I SET THE REAL TIME CLOCK? 50

APPENDIX C – DUALPRO SETUP 52

Introduction

The Lorox™ utilizes high-performance Lorox Probe technology to provide cost-effective and reliable oxygen sensing and control in low process temperature applications.

Your Lorox™ system is covered by a one-year conditional warranty as described on the enclosed Warranty Card. Please be sure to complete and return your Warranty Registration card so that Marathon can provide you with the most responsive service and support.

Package Contents

Please verify that you have received the following:

1. Lorox™ controller enclosure with Dualpro™ controller
2. System wiring and piping diagrams
3. Dualpro Operation Manual F200001
4. Dualpro Programming and Basic Language Handbook F200043
5. Lorox Installation and Operations Manual F200081
6. Lorox Controller Installation and Operations Manual F200082

If your shipment is missing any of these items please contact Marathon Sensors immediately.

Installation

Location

Choose a location for installation of the Lorox™ enclosure where the ambient temperatures will not exceed 130°F. Optional air conditioning or vortex cooling systems can be added to the package if required.

The Lorox™ control package requires ventilation in order to maintain adequate reference air when using an internal pump. Do not position the enclosure where process or combustion exhaust can be pulled into system enclosure.

The system can also be configured for instrument air. It is necessary to use shop instrument air for probe reference air if an air conditioning unit is installed.

Electrical Connections

Following the enclosed wiring diagram, attach a 115VAC power source to the incoming power terminals. The power source to the enclosure should not share power with heavy motors, pumps, welding equipment, or inductive loads. An isolated 115VAC transformer for instrument power is preferred.

The following diagram shows the basic electrical connections and signal connections between the Lorox sensor and the control panel.

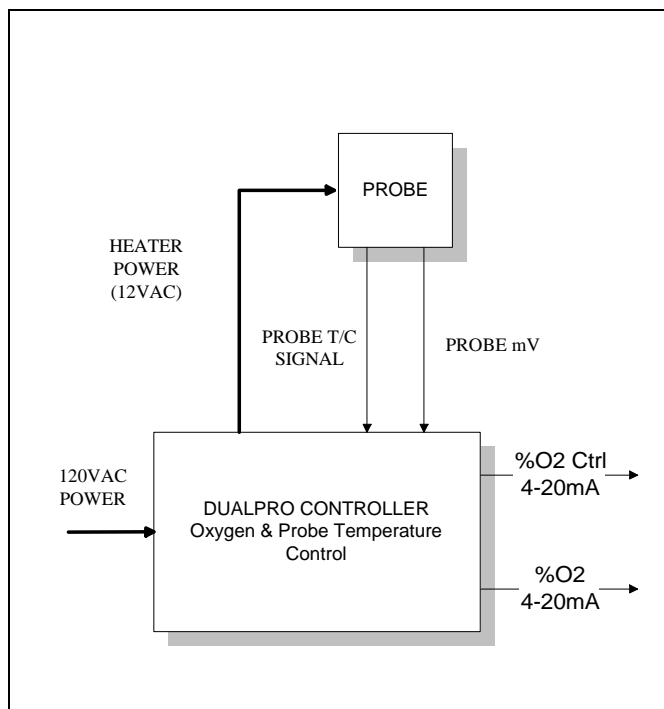

Figure 1 Basic Lorox Connections

The measurement part of the system consists of a self-heating Lorox probe and the Dualpro, a dual loop programmable controller. The power to the probe's internal heater is controlled by the first control loop of the Dualpro. This control is accomplished by monitoring the probes internal thermocouple. This temperature reading and the probe's millivolt signal are used to calculate the oxygen level in the process. This value can be used to control the process oxygen using the one for two 4-20mA loops or control contract on the controller.

The probe temperature sensor is a type "K" thermocouple. The Dualpro measures this signal with cold junction compensation. This temperature input is used to calculate the oxygen level and control the probe's internal heater. The millivolt signal from the probe can be adjusted manually or automatically when a zero and span cal gas are used to calibrate and check the Lorox probe. Refer to the section on calibration for more information on this feature.

AC Power Connections

All the electrical connections for the system are made on the terminal blocks located inside the Lorox enclosure. The AC power connections are located on the upper right-hand side of the enclosure subpanel. There is a single fused AC power ladder. The terminals labeled as A1000 (Line), A1020 (Neutral) feed the control and alarm circuits. The terminals labeled A1001 (Line) and A1021 (Neutral) feed the instrument power circuit. There is a subpanel jumper, 119JP, that provides a power disconnect to the rear panel of the Dualpro. There are additional 1.0A fuses for the instrument's alarm, event, and control circuits. Removing the jumper will remove all power to the rear of the instrument.

A separate 4.0 Amp fuse protects the probe heater circuit. This power is applied to the probe heater through a relay under the control of the Dualpro.

DC Signal Connections

Separate DC signal terminal blocks are located on the left-hand side of the subpanel. Terminal blocks are provided for field wiring to the 4-20mA control loops and the probe millivolt signal. The thermocouple wire should be connected directly to the instrument using K type extension wire. There are several considerations when running signal wire for this or any measurement system;

- All signal wiring should be kept separate from any AC power cabling.
- Do not run DC signal wiring closely bundled or in parallel with power cables.
- Use shielded cable for the signals.
- Tie the shield to a single ground point at one end of the cable, preferably at the controller ground.

Dualpro Connections

The Dualpro reads the signal inputs from the Lorox probe. From these inputs it calculates the process oxygen potential and controls the probe's internal heater. The Dualpro also has the capability of controlling the trim air for the process with either a control contract #2 or a 4-20mA loop. The following are typical connections for the Dualpro;

Control Connections

- Control 1 – Probe heater (Loop 1)
- Control 2 – Available for oxygen control (Loop 2)
- Analog 1 – Scaled for 0-25% oxygen (4-20mA)
- Analog 2 – Available for process control
- Event 0 – Zero cal gas flow control
- Event 1 – Span cal gas flow control

Input Connections

- Input 1 – Probe type K thermocouple
- Input 2 – Probe millivolt signal
- Input 3 – Not used

If control contract #2 is being used, the two 4-20mA loops can be configured to provide retransmission of the oxygen and temperature levels of the probe.

The instrument also has four internal events numbered event 0, 1, 2, and 3. Event 0 is used to control the zero gas (air) and event 1 is used to control the span gas (typically 1% - 2% oxygen).

Gas Sampling Connections

Connect the incoming zero and span gases to the inlets on the top left side of the enclosure. The connections for the span and zero gasses are ¼" CPI fitting with nut and ferrule included. These sources should have a maximum pressure of 5PSI and a flow of 5 – 10 SCFH.

Marathon Sensors Inc.

The connection of reference air (shop air option installed) is a 1/4" female NPT on the top left side of the panel. This air supply should have a maximum pressure of 150 PSI. Adjust the internal pressure gauge/filter assembly for a pressure of <10 PSI with a flow rate of 2 SCFH

The gas and reference air exits at the top right side of the enclosure through 1/4" CPI fittings. It is recommended that continuous metal tubing be used to connect the cal and reference gasses to the Lorox probe junction box.

The following diagram shows a typical sample gas installation.

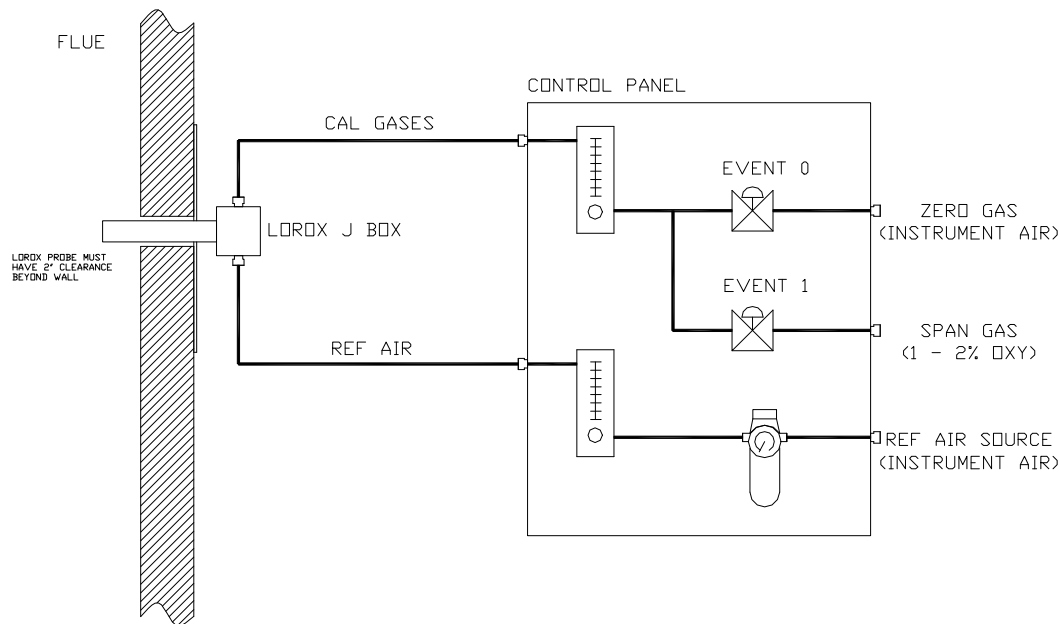

Figure 2 Typical Gas Line Connections

The reference air rotometer on the left side of the enclosure should be adjusted for a 1.0 SCFH (mid-scale) reading.

Adjust the calibration gas rotometer on the right side to 5 SCFH (mid-scale). See the System Operation section for instructions on how to manually operate the calibration gas events.

The term zero gas for air (20.9% oxygen) is used here because when air is injected at the face of the probe it should produce a 0 mV output. When the span gas (1-2% oxygen) is injected at the face of the probe it should produce a positive millivolt output. Therefore the terms zero and span refer to the resulting millivolt output of the probe not the levels of oxygen used to generate these levels.

System Operation

Normal Operation

During normal operation the Dualpro will display the probe temperature (Loop 1) and the process oxygen (Loop 2). The Dualpro is configured to control probe temperature using control contact 1. It can also be configured to control the oxygen level of the measured process by using control contact 2 or one of two 4-20mA signal loops. Refer to the Dualpro manual F200001 for a detailed description of the instrument's control capabilities. Also refer to the Lorox system drawings to see where the required connections points are for your Lorox application.

Automatic Loop Control

The Dualpro controls the probe temperature and process oxygen automatically using the standard automatic control features of the instrument. In Automatic Mode the measured process value is displayed in the PROCESS display and the set point is displayed in the SET display. Any control action is computed based upon the PID parameters and changes in the Lorox probe temperature and millivolt levels. Pressing and holding the [Left Arrow] key will cause the SET display to show the percent output control action for either loop when that loop is actively displayed.

The loop displays correspond with the LED indicators on the right and left side of the SETPOINT and PROCESS displays. The LOOP 1 LED is lit when the loop 1 process and set point displays are shown. The LOOP 2 LED is lit when the loop 2 process and set point displays are shown.

Pressing [Shift] key shifts the display representation from one loop to the other as indicated by the loop LED's. Loop1 is set to control the probe temperature, loop 2 is set to control the oxygen level of the process.

Refer to the following figure for locations of the keys and indicators on the Dualpro.

Conditional Tests of the Lorox System

The Lorox program running on the Dualpro tests a number of conditions during normal operations. This program is running in the background at all times. It performs the following tasks:

- Works in conjunction with the Basic program to calculate in floating point, the required slope settings for the millivolt input.
- Initiates a calibration sequence for zero and span when a operator request is made or when the time setting matches the instrument's real time clock.
- Automatically operates the zero (air) gas and span gas solenoids during calibration.
- Monitors alarm conditions for probe heating, calibration value limits, and program operation. (See System Alarms for details)

System Alarms

The system can generate a series of alarms and displays these as PAL's (Program Alarms). The following list explains these PAL codes. Refer to the troubleshooting section for help in resolving problems that may occur.

It is possible to clear these program alarms by pressing the [Enter] key. Some alarms such as the PROBE TOO HOT or PROBE NOT HEATING alarm will not clear until the fault condition is corrected. During an alarm condition, the calibration offset and slope values are set to default values of 0.0 offset and 1.00 slope.

Table 1 Program Alarm Codes

PAL Code	Alarm Description	Condition	Cause
201	PROBE NOT HEATING	Occurs if the probe does not achieved the required temperature set point (750°C) once the set point has been entered. A fixed time limit of 30 minutes is set once the set point is entered. This alarm will also occur if the probe temperature drops 50° below set point during normal operation. It will continue to appear if acknowledged until the heat reaches normal levels.	<ul style="list-style-type: none"> • The probe heater has failed. • The fuse for the probe heater circuit has opened. • The heater circuit relay has failed open. • The control contact in the Dualpro has failed open or the control parameters for Loop 1 have been changed.
202	PROBE TOO HOT	Occurs if the probe temperature rises 50° above set point. It will continue to appear if acknowledged until the heat reaches normal levels.	<ul style="list-style-type: none"> • Loop 1 has been left in manual mode at 100% output. • Control relay of heater circuit has failed closed.
205	CAL OFFSET TOO LOW	Appears if the probe millivolt level measured during the offset cycle is less than -50mV. While the alarm is active, the default offset and slope numbers are used. The system will initialize all calibration values and stop the calibration sequence when this alarm is acknowledged.	Span gas has been switched with the probe's reference air. This would cause a polarity change in the probe output during a zero calibration.
206	CAL OFFSET TOO HIGH	Appears if the probe millivolt level measured during the offset cycle is greater than 50mV. While the alarm is active, the default offset and slope numbers are used. The system will initialize all calibration values and stop the calibration sequence when this alarm is acknowledged.	<ul style="list-style-type: none"> • Zero gas is not available • Zero gas solenoid has failed to function, leaving the process gas in the probe. • An improper span value has been entered in N1.
207	CAL SPAN TOO LOW	Appears if the slope calculation does not compare to the value in the Basic program (data transfer problem) or if the calculated slope is less than -1.999.	<ul style="list-style-type: none"> • Span gas is not available • Span gas solenoid has failed to function, leaving the process gas in the probe

Marathon Sensors Inc.

			<ul style="list-style-type: none"> An improper span value has been entered in N1.
208	CAL SPAN TOO HIGH	Set if the probe millivolt level is higher than 409mV or the slope calculation is greater than 1.999.	
300	BASIC PROGRAM STOP	Set if the Basic program has stop and has not reset the 120 second watchdog timer running in the Lorox program. In most situations the program will restart the Basic program.	<ul style="list-style-type: none"> Span gas is not available Span gas solenoid has failed to function, leaving the process gas in the probe An improper span value has been entered in N1.

The system can also be configured for a process alarm. This function is wired to Alarm 1 contact through relay 119CR in the system enclosure. The alarm can be setup for deviation, band, or high/low limit alarms associated with the oxygen set point. See the Alarms section of the Dualpro manual for more information on how to configure these alarms. Normally open and normally closed contracts are available on relay 119CR.

The Dualpro Front Panel

Refer to the following figure during references to the DUALPRO'S indicators and keys.

Figure 3 Dualpro Front Panel

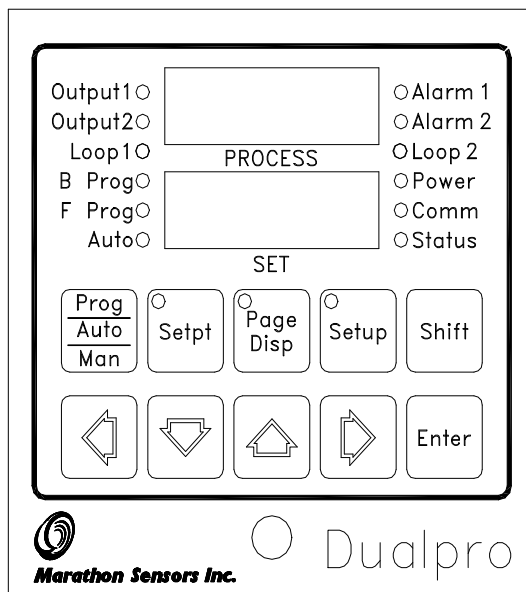

All information entered into the instrument is stored in non-volatile memory. All the setups are entered using the [Setup] key. Some of the parameters opened by the [Setup] key can be password protected. The DUALPRO is shipped from the factory without a password.

The DUALPRO front panel consists of an upper and lower segment Light Emitting Diode (LED) display, twelve LED indicators, and ten membrane keypads (keys). The upper segmented display shows the process value in normal operation and is referred to as the PROCESS window. When entering parameters, this display will show a message identifying the parameter being entered. The lower display in normal operation will show the process setpoint when in auto and the control percent output when in manual. It is referred to as the SET window. When entering parameters, this display will show the value of the parameter being entered. This display will temporarily show other data dependent on certain keys being held down as described in the keypad section.

The twelve LED indicators provide information on the operation of the DUALPRO as follows:

The Dualpro Keypad

The functions of the ten membrane keys may change when the DUALPRO is placed into different modes. This describes the keys if activated from the normal mode of operation. The descriptions of the various modes will describe how the keys are used in that mode.

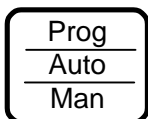

The [Prog|Auto|Man] key provides control of the foreground program, background program, Loop 1, and Loop 2. The foreground and background programs may be separately stopped, viewed, run, continued, or placed in hold. Loop 1 and Loop 2 may be separately placed in either manual or automatic mode. Press this key twice to reach the other options for the background program start or loop control.



The [Setpt] key allows the user to edit the setpoint (SP1, SP2), reference number (RN), and operator-input numbers (N1 - N15). The operator-input numbers have special assignments for the Lorox application. See the section on Automatic Lorox Probe Calibration of a list of these special assignments.



The [Page Disp] key allows the status display page to be viewed and allows a limited number of features to be edited. See the Display Menu section for an explanation of these menus.



Pressing the [Setup] key places the DUALPRO into the parameter entry mode for all setup parameters. See the Setup Menu section for an explanation of these menus.



Pressing the [Shift] key shifts the display representation from one loop to the other as indicated by the loop LED's. It also performs as the second key for most dual key operations. The [Shift] key also can be used to cycle through the parameters of other keys in a reverse direction. In

Marathon Sensors Inc.

multi-key operations, always press and hold the [Shift] key then press the other keys.



The [Enter] key has no function by itself under normal operation. However, it is used to cycle through, in a forward direction, the parameters of the other keys.

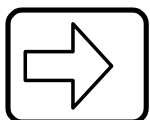

The [Right Arrow] is only used when in manual mode or parameter entry mode. Each press of the [Right Arrow] key will cause the percent output of the displayed loop to increase by approximately 10% when the loop is in Manual mode.



The [Up Arrow] is used to increase the edited digit in parameter entry mode and to manually adjust the percent output in the manual control mode. Each press of the [Up Arrow] key causes the percent output of the displayed loop to increase by 1%.

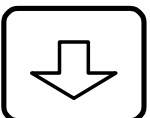

The [Down Arrow] is used to decrease the edited digit in parameter entry mode and to manually adjust the percent output in the manual control mode. Each press of the [Down Arrow] key causes the percent output of the displayed loop to decrease by 1%.

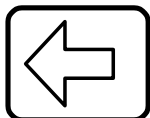

The [Left Arrow] is only used when in manual mode or parameter entry mode. Each press of the [Left Arrow] key will cause the percent output of the displayed loop to decrease by approximately 10%.



+



Pressing [Shift]+[Up] two key combination performs an LED test whereby every segment and decimal point of the fourteen segment displays and every LED is illuminated. Should an LED not light up, it is defective. If any part of the display does not light during this test, it is defective.



+

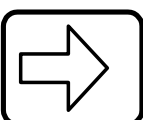

The [Shift]+[Right] two key combination determines how the two control loops will be displayed. Pressing [Page Disp] key in this mode allows the display to either scan between Loop 1 and Loop 2, or to display only the loop placed in hold. The loop to be placed in hold may be determined by pressing the [Shift] key. The appropriate loop LED will flash while it is placed in hold mode.





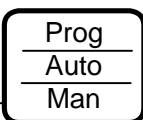

+







The [Shift]+[Prog|Auto|Man] two key combination sets up

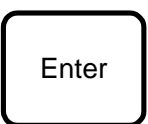

the cold junction trim. The cold junction temperature can then be adjusted with the [Down] or [Up] keys. Exit by pressing [Enter].



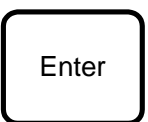

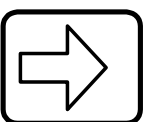
 +  The [Shift]+[Setpt] two key combination opens the program editor option.

 +  The [Shift]+[Page Disp] two key combination sets up the password. Any order of keys except for [Shift] or [Enter] can be used as passwords. Up to nine key presses can be used. Press [Enter] to save a newly set password. The number in the SET display will count the number of keys entered. Pressing [Enter] without pressing any other key (i.e.: SET display = 0) will enter "no" password. The lock level setting and the lock level required for each parameter determine whether or not a password is needed on each parameter. The lock levels for each parameter are listed in the Dualpro Operators Manual. A lock level of 0 is the most restrictive. A lock level of 3 is the most open.

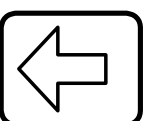
 +  The [Shift]+[Enter] two key combination will start the probe maintenance routine, if it is enabled. This function is automatically disabled in the Lorox application.

 then  then  then  The [Shift] then [Enter] then [Setpt] then [Right] four-key sequence will set the memory of the instrument to default settings. If the lock level is less than 3, a password will be required to execute this function. **Do not** set the CLR PG (Clear Program) option to Yes. This will clear the Lorox background program necessary to run the Lorox application.

 then  then  then  The [Shift] then [Enter] then [Setpt] then [Left] four-key sequence will test the memory. If the lock level is less than 3, a password will be required to execute this function.

 then  then  then  The [Shift] then [Enter] then [Setpt] then [Page Disp]

four-key sequence will place the Dualpro in INPUT CALIBRATION MODE. If the lock level is less than 3, a password will be required to execute this function.

Setpoint Key

The [Setpt] is important in the operation of the Lorox because the parameters in this key's menu control the probe operating temperature, calibration sample and delay times, and calibration start times. It is also possible to start a calibration manually using the N5 parameter in the [Setpt] key menu. The following figure explains the parameter assignments for the Lorox application.

Figure 4 Setpt Key Menu

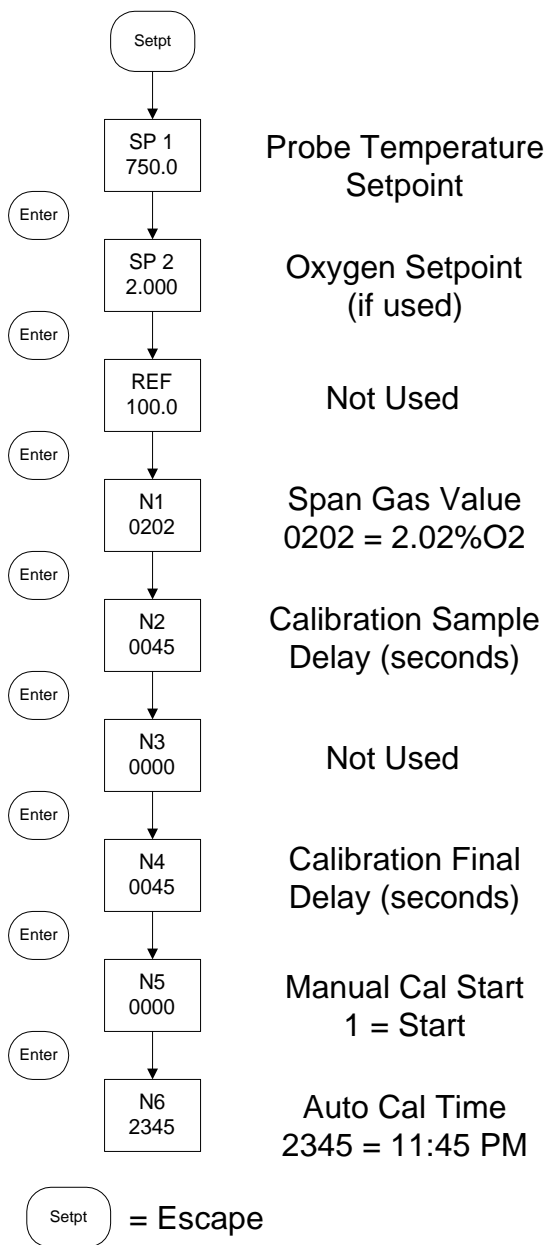

Entering Loop Set Points

To start the measurement process it is necessary to enter the set point for the probe's internal heater. Follow the above figure and enter the set point by doing the following;

- Press the [Setpt] key

Marathon Sensors Inc.

- The PROCESS display shows SP1, the SET display shows the loop 1 set point in degrees Celsius.
- Press the [LEFT] key to move the flashing cursor to the digit to change.
- Press the [UP] or [DOWN] key to change the flashing digit value.
- Enter the required temperature of 750°C or 1382°F. (Celsius is the default)
- Press [Setpt] again to exit.

If the Auto LED indicator is not light while the display shows the Loop 1 process, it will be necessary to set Loop 1 to automatic control mode. Place Loop 1 in automatic mode by doing the following;

- Press the [Prog/Auto/Man] key twice, the upper display will indicate FPROG
- Press the [Enter] key once, the display will indicate BPROG
- Press the [Enter] key once, the display will indicate LP 1
- Press the [UP] key to change MAN to AUTO.
- Press the [Prog/Auto/Man] key to exit

The LOROX probe will take about 20 minutes to heat from an ambient temperature to an operating temperature of 750°C (1380°F). The oxygen display in loop 2 is always active but this value is not valid until the probe has reached the required temperature set point.

A timer (timer TD) starts running as soon as the set point for Loop 1 has changed to 750°C. If the probe does not achieve set point within 30 minutes an alarm 201 (probe not heating) is set. If the probe achieves the required temperature within the time limit the system will continue to control probe temperature and look for calibration requires. See the Display Parameters section for an explanation of the timer menu.

Both the analog outputs can be configured to retransmit the process values or transmit percent output levels for process control. A set point has to be entered for Loop 2 if control of the oxygen process is required. Both analog outputs will provide a 4-20mA output proportional to 0-100% control output or a process range such as 0 to 21% oxygen. The system default settings are oxygen 0-25% on analog output channel 1 and probe temperature 0-1000°C.

Display Parameters

The following figures show the structure of the Display menu. This menu is accessed by pressing the [Page Disp] key on the Dualpro front panel. Most of the parameters shown in these menus are for display purposes only. There are a few special cases that allow you to manually control some features of the instrument such as the digital events, both internal and external (if connected). A detailed explanation follows these figures.

Any menu page heading maybe displayed when you press the [Page Disp] key. This depends on the last page you were viewing. It is possible to advance to the next menu parameter by pressing [Down] key. It is possible to move forward or backward in the menu headings by pressing the [Right] or [Left] arrow keys. Pressing the [Page Disp] key again exits from the Setup menu.

Figure 5 Display Parameters

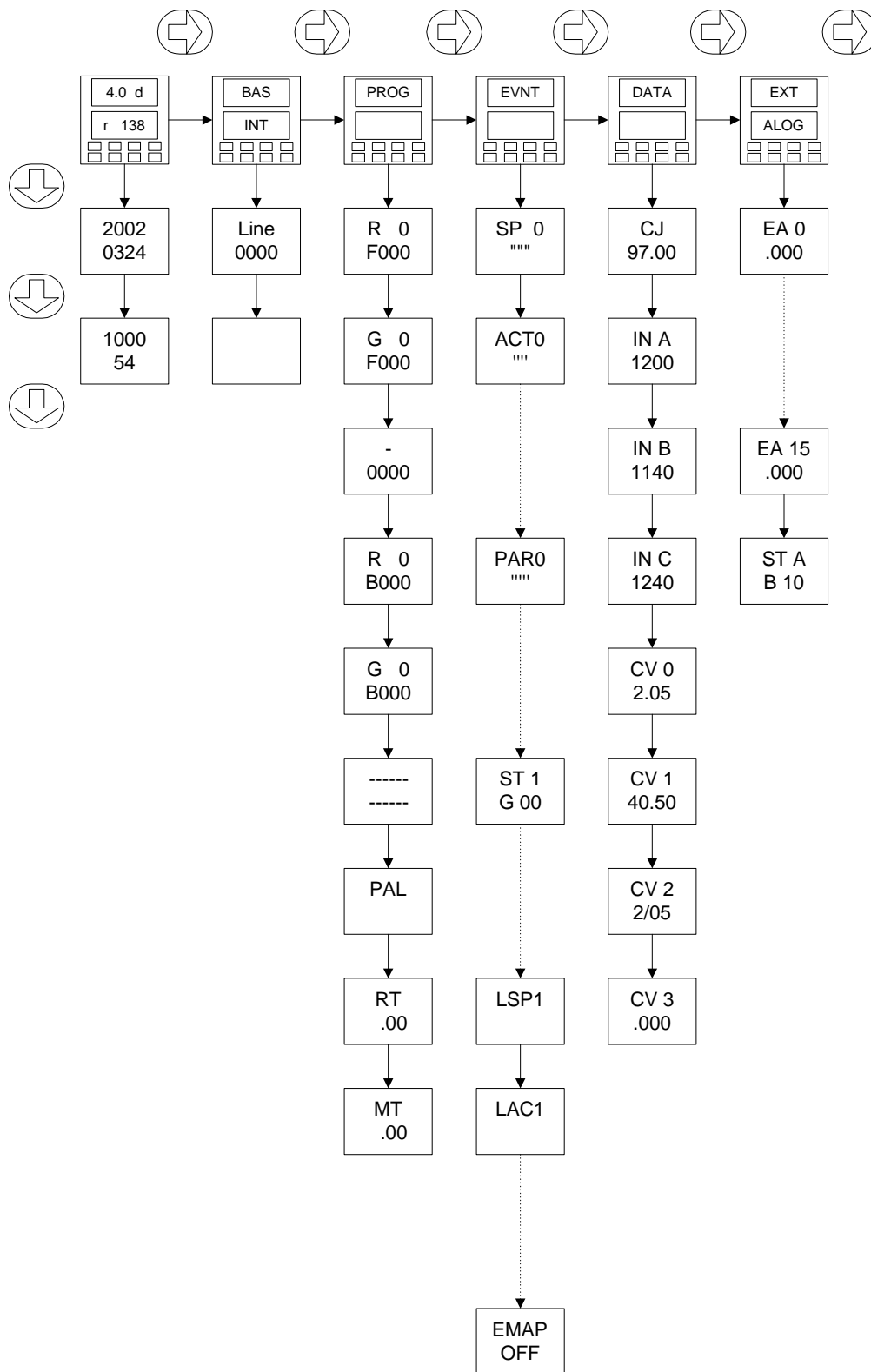
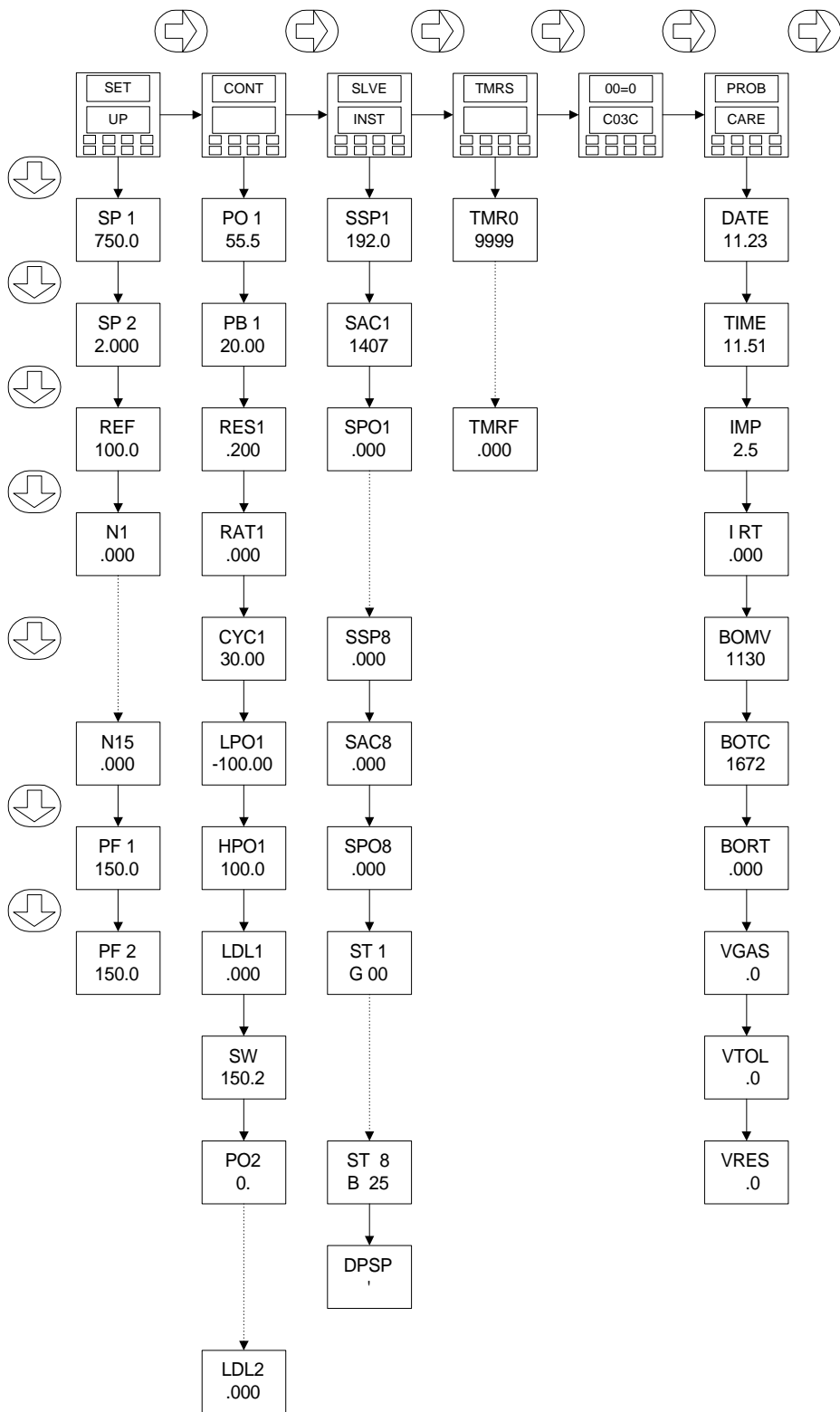

Figure 6 Display Parameters (continued)



Marathon Sensors Inc.

The following tables are detailed descriptions of each menu item in the Display menu tree.

VERSION Display Page	Description
4.0 d r 138	Displays the firmware revision as Version 4.0 Dualpro revision 138
2002 0404	Displays the year, month, and date. The time and date can be changed at this point by pressing [Shift]+[Setpt]
1428 38	Displays the hour (military time), minutes and seconds.

BASIC PROGRAM Display Page	Description
BAS INT	Internal Basic program display menu heading
Line 0120	Indicates the line number being executed by the Basic program area of the Dualpro. The Lorox application uses Basic to calculate equivalent millivolts and slopes for the calibration routine
	PM0\$ program display window (usually blank)
	PM1\$ program display window (usually blank)

PROGRAM Display Page	Description
PROG	Program display menu heading
R 0 F000	Displays the running line number (R) and the foreground program number (F). The foreground program is typically used of recipes
G 0 F000	Displays the subroutine (G) and the calling program number (F) of a running foreground program
- 0000	Indicates the op code and data of the currently executing program line in an active foreground program
R 0 B000	Displays the running line number (R) and the background program number (B). A background program running in the Lorox application
G 0 B000	Displays the subroutine (G) and the calling program number (B) of a running background program
CP.ZE 0001	Indicates the op code and data of the currently executing program line in the background program
PAL	Displays any active Program Alarms. This display pops up when an alarm occurs.
RT .00	Displays remaining time in a foreground recipe step. It is possible to edit this time while the recipe is running by pressing [Shift]+[Setpt]
MT .00	Displays the Master timer used in V3.5* recipes. This time is displayed as hours.minutes and is set by the "T" recipe opcode.

Marathon Sensors Inc.

EVENTS Display Page	Description
EVNT	Event display menu heading
SP 0 	Displays the set point request for the internal events of the Dualpro. These events can be turned on/off manually by pressing [Shift]+[Setpt] and then the arrow keys to select the event or turn it on/off. Only event numbers 0 – 3 are valid.
ACT0 	Displays the active events that are being monitored by the instrument and confirmed as on. An on state is indicated by a tick mark for each event.
SP 1 	Displays the set point request for the first external OPTO events board connected to the Dualpro. These events can be turned on/off manually by pressing [Shift]+[Setpt] and then the arrow keys to select the event or turn it on/off. Valid events can be 0 – 3, 7, or 15 depending on the size of the attached event board.
ACT1 	Displays the active events that are being monitored by the instrument and confirmed as on. An on state is indicated by a tick mark for each event.
SP 2 	Displays the set point request for the second external OPTO events board connected to the Dualpro. These events can be turned on/off manually by pressing [Shift]+[Setpt] and then the arrow keys to select the event or turn it on/off. Valid events can be 0 – 3, 7, or 15 depending on the size of the attached event board.
ACT2 	Displays the active events that are being monitored by the instrument and confirmed as on. An on state is indicated by a tick mark for each event.
SP 3 	Displays the set point request for the third external OPTO events board connected to the Dualpro. These events can be turned on/off manually by pressing [Shift]+[Setpt] and then the arrow keys to select the event or turn it on/off. Valid events can be 0 – 3, 7, or 15 depending on the size of the attached event board.
ACT3 	Displays the active events that are being monitored by the instrument and confirmed as on. An on state is indicated by a tick mark for each event.
SP 4 	Displays the set point request for the fourth external OPTO events board connected to the Dualpro. These events can be turned on/off manually by pressing [Shift]+[Setpt] and then the arrow keys to select the event or turn it on/off. Valid events can be 0 – 3, 7, or 15 depending on the size of the attached event board.
ACT4 	Displays the active events that are being monitored by the instrument and confirmed as on. An on state is indicated by a tick mark for each event.
PAR0 	Displays the event partition of the internal events. A tick mark indicates the event is set as an output. This state is set in the Events Setup Page.
PAR1 	Displays the event partition of the events on the first external events board. A tick mark indicates the event is set as an output. This state is set in the Events Setup Page.
PAR2 	Displays the event partition of the events on the second external events board. A tick mark indicates the event is set as an output. This state is set in the Events Setup Page.
PAR3 	Displays the event partition of the events on the third external events board. A tick mark indicates the event is set as an output. This state is set in the Events Setup Page.

Marathon Sensors Inc.

PAR4 	Displays the event partition of the events on the fourth external events board. A tick mark indicates the event is set as an output. This state is set in the Events Setup Page.
ST 1 G 00	Indicates good (G) communications status of bad (B) status with the first external board. A "B" is show if no board is attached.
ST 2 B 00	Indicates good (G) communications status of bad (B) status with the second external board. A "B" is show if no board is attached.
ST 3 B 00	Indicates good (G) communications status of bad (B) status with the third external board. A "B" is show if no board is attached.
ST 4 B 00	Indicates good (G) communications status of bad (B) status with the fourth external board. A "B" is show if no board is attached.
LSP1	Indicates if any logical events are set. This feature is not used for Lorox.
LAC1	Indicates if any logical events are on. This feature is not used for Lorox.
LSP2	Indicates if any logical events are set. This feature is not used for Lorox.
LAC2	Indicates if any logical events are on. This feature is not used for Lorox.
LSP3	Indicates if any logical events are set. This feature is not used for Lorox.
LAC3	Indicates if any logical events are on. This feature is not used for Lorox.
LSP4	Indicates if any logical events are set. This feature is not used for Lorox.
LAC4	Indicates if any logical events are on. This feature is not used for Lorox.
EMAP OFF	This display indicates if the event mapping features of the Dualpro are turned on or off. The Lorox program turns this feature off automatically.

DATA Display Page	Description
DATA	DATA display menu heading
CJ 39.00	Cold junction reading in °C. It can also be used to measure the internal cabinet temperature of the system.
IN A 750.0	This is the measured temperature of the Lorox probe. This reading is used to control the probe heater as well as calculate the oxygen level.
IN B 67.50	This is the measured millivolt reading from the Lorox probe. This reading is used to calculate the oxygen reading along with the temperature reading.
IN C 3500	This is the measured value at input C. This input is turned off in the Lorox application.
CV 0 1.010	Calculated value 0 displays the actual oxygen level measured by the Lorox probe.
CV 1 .000	Calculated value 1 is not used in this application.
CV 2 1.010	Calculated value 2 displays the same as CV 0.
CV 3 66.59	Calculated value 3 displays the equivalent millivolt reading expected from the Lorox probe based in the span gas value entered in N1 and the actual probe temperature from IN A. This value is calculated by the Basic program.

Marathon Sensors Inc.

EXTERNAL ANALOG Display Page	Description
EXT ALOG	External Analog display menu heading
EA 0 through EA 15	These displays indicate the measured values from each of possibly sixteen input modules of an external analog input board.
ST A B 10	Indicates the communication status of the external OPTO analog input board. "G" indicates good status, "B" indicates bad status or no board attached.

SET UP Display Page	Description
SET UP	Set Up display menu heading
SP 1 750.0	Set point for loop 1. This is the probe temperature set point in the Lorox application.
SP 2 1.000	Set point for loop 2. This is set point is unassigned in the Lorox application but is shown here as an oxygen set point.
REF 200.0	Reference Number, set in the [Setpt] key menu
N1 through N15	Values of N1 through N15. These numbers are set in the [Setpt] key menu. Some of these numbers have particular meanings in the Lorox application. See section on Automatic Lorox Probe Calibration of a detailed explanation of these settings.
PF 1 150.0	Process factor 1 for carbon control. The default for this number is 150.
PF 2 150.0	Process factor 2 for dew point control. The default for this number is 150.

CONTROL Display Page	Description
CONT	Control display menu heading
PO 1 0100	Actual percent output of loop 1. The same value can be seen by pressing the [Left] key while viewing the loop 1 process display.
PB 1 20.00	Proportional band setting for loop 1. This number is used by the tuning algorithm for loop 1. Display is in loop 1 process units (°C)
RES 1 .200	Reset setting for loop 1. This number is used by the tuning algorithm for loop 1
RAT1 .000	Rate setting for loop 1. This number is used by the tuning algorithm for loop 1
CYC1 30.00	Cycle time in seconds for the control contract assigned to loop 1.
LPO1 .000	Low percent output for loop 1. Usually set to 0.
HPO1	High percent output for loop 1. Usually set to 100

Marathon Sensors Inc.

100.0	
LDL1 .000	Load line display for loop 1. Not used in this application
SW 150.3	Slidewire reading from Input C. Not used in this application.
PO 2 0100	Actual percent output of loop 2. The same value can be seen by pressing the [Left] key while viewing the loop 2 process display.
PB 2 20.00	Proportional band setting for loop 2. This number is used by the tuning algorithm for loop 2. Display is in loop 2 process units.
RES 2 .200	Reset setting for loop 2. This number is used by the tuning algorithm for loop 2.
RAT2 .000	Rate setting for loop 2. This number is used by the tuning algorithm for loop 2.
CYC2 30.00	Cycle time in seconds for the control contract assigned to loop 2.
LPO2 .000	Low percent output for loop 2. Usually set to 0.
HPO2 100.0	High percent output for loop 2. Usually set to 100
LDL2 .000	Load line display for loop 2. Not used in this application

SLAVE INSTRUMENT Display Page	Description
SLVE INST	Slave Instruments display menu heading
SPP1 through SPP8	Shows the set point requests being sent by the Dualpro to any attached slave controllers. A maximum of eight slaves are allowed.
SAC1 through SAC8	Shows the actual set points being sent to the Dualpro from any attached slave controllers. A maximum of eight slaves are allowed.
SPO1 through SPO8	Shows the percent output of each slave sent to the Dualpro by any attached slave controllers. A maximum of eight slaves are allowed.
ST 1 through ST8	Shows the communications status of any attached slave controllers. A maximum of eight slaves are allowed.
DPST 	Shows the activity of any attached controllers on the Dualpro's Auxiliary bus port. Up to fifteen instruments are allowed in certain port settings.

TIMERS Display Page	Description
TMRS	Timers display menu heading
TMR0 through TMR15	Displays the timer settings for each of sixteen timers available in the Dualpro. Timer values can be changed by pressing [Shift]+[Setpt] at the particular timer display. See "Can I change the calibration timers during a calibration?" in the Troubleshooting section of this manual for a detail of the timer definitions.

Marathon Sensors Inc.

MEMORY MAP Display Page	Description
00=0 C13C	Memory Map display menu heading. This display is for advanced users only. Do not attempt to change any values here unless you know what they are.

PROBE CARE Display Page	Description
PROB CARE	Probe Care display menu heading. This feature is disabled in the Lorox application.
DATE .00	Date when last probe care test was run.
TIME .00	Time when last probe care test was run.
IMP .0	Probe impedance measurement made during last probe care test.
I RT .000	Probe recovery time in seconds during the last probe care test.
BOMV .000	Actual millivolt reading during probe burn off cycle.
BOTC .000	Actual temperature reading from probe during burn off cycle.
BORT .000	Recovery time in seconds for probe following the burn off cycle.
VGAS .0	Verification gas value (%O ₂) used during the last oxygen probe test.
VTOL .0	Verification test tolerance (%O ₂) during the last oxygen probe test.
VRES .0	Verification gas measured (%O ₂) during the last oxygen probe test.

Setup Parameters

The following figures show the structure of the Setup menu tree. These menus are accessed by pressing the [Setup] key on the Dualpro front panel. The parameters are grouped by function under specific menu headings. Some or these functions are not required in this application. Some parameters are pre-set by the Lorox program. These are indicated in the following figures as gray blocks. The values shown are not necessarily the values required in your application. Make sure you have filled out the setup parameter work sheet in Appendix C of this manual to document the actual setup parameters in your application. A detailed explanation follows these figures.

Any menu page heading may be displayed when you press the [Setup] key. This depends on the last page you were viewing. It is possible to advance to the next menu parameter by pressing [Enter]. It is possible to move forward or backward in the menu headings by pressing the [Right] or [Left] arrow keys. Pressing the [Setup] key again exits from the Setup menu.

Menu parameters are changed by moving the flashing cursor through the parameter number by pressing [Right] or [Left]. The value of the flashing digit can be changed by pressing the [Up] or [Down] keys. Some parameters provide a selection list that can be changed with the [Up] or [Down] keys. The changed value is entered into the instrument when the [Enter] key is pressed.

Repeat functions are shown as dotted lines in the following figures. For example there are three inputs for the instrument. Similar parameters are available for all three inputs, so these functions are shown for input A (IN A), and implied for inputs B and C.

Figure 7 Setup Menu

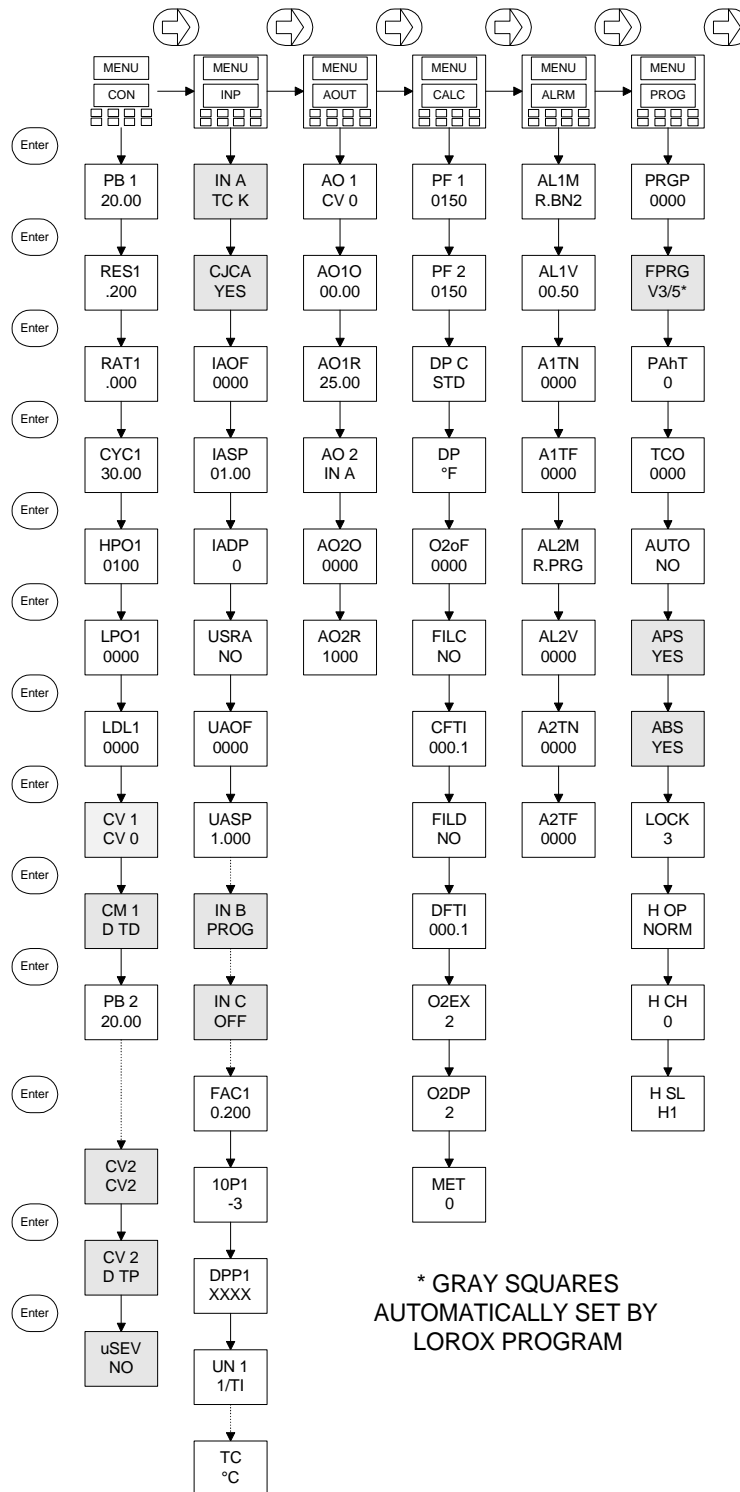
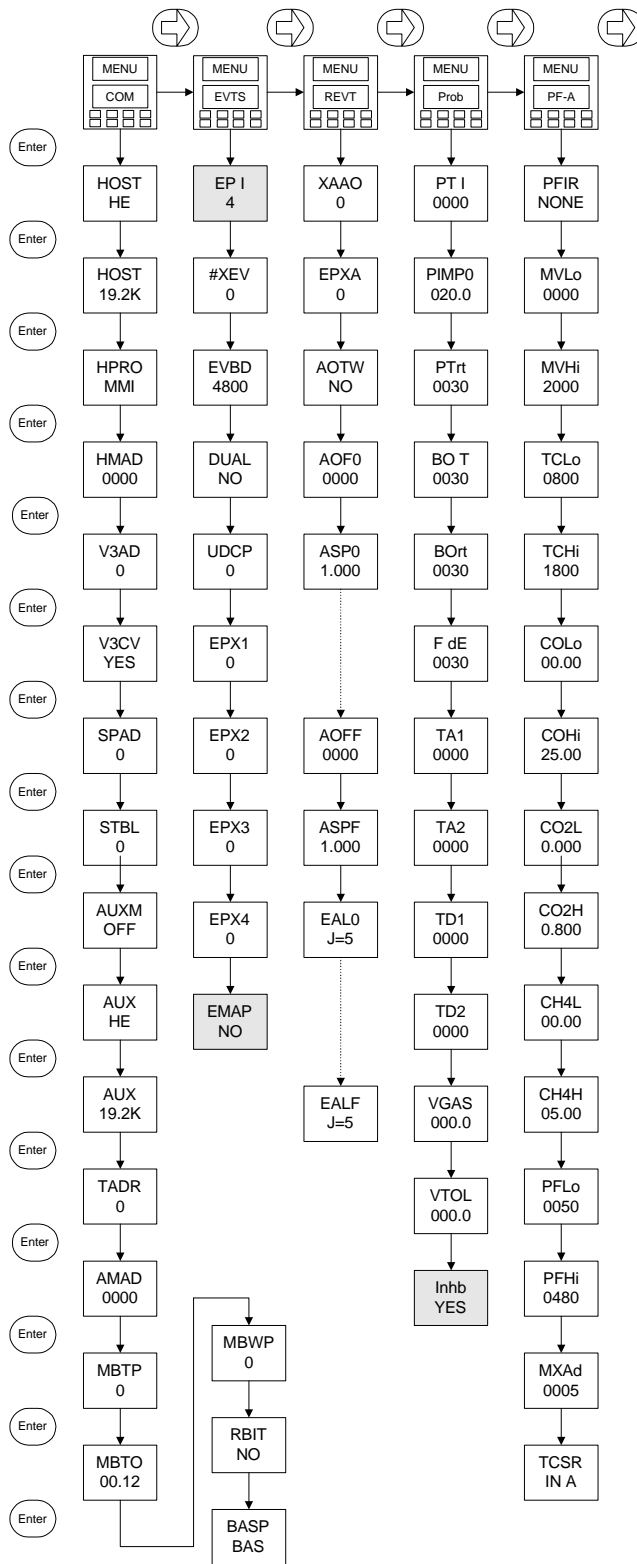

Figure 8 Setup Menu (continued)



Marathon Sensors Inc.

CONTROL Setup Page	Description
MENU CONT	Control setup menu heading
PB 1 0020	Proportional band setting for loop 1. This number is used by the tuning algorithm for loop 1. Display is in loop 1 process units (°C)
RES 1 00.20	Reset setting for loop 1. This number is used by the tuning algorithm for loop 1
RAT1 00.00	Rate setting for loop 1. This number is used by the tuning algorithm for loop 1
CYC1 0030	Cycle time in seconds for the control contract assigned to loop 1.
HPO1 0100	High percent output for loop 1. Set to 100 in the Lorox application.
LPO1 0000	Low percent output for loop 1. Set to 0 in the Lorox application.
LDL1 0000	Load line display for loop 1. Not used in this application
CV 1 IN A	Selects Input A, probe temperature, as the control parameter for Loop 1
CM 1 D TP	Control mode for Loop 1 is selected to be Direct, Time Proportioning. This mode uses Control Contract 1 to regulate the probe heater.
PB 2 0020	Proportional band setting for loop 2. This number is used by the tuning algorithm for loop 2. Display is in loop 2 process units.
RES 2 00.20	Reset setting for loop 2. This number is used by the tuning algorithm for loop 2.
RAT2 00.00	Rate setting for loop 2. This number is used by the tuning algorithm for loop 2.
CYC2 0300	Cycle time in seconds for the control contract assigned to loop 2.
HPO2 0100	High percent output for loop 2. Usually set to 100
LPO2 0000	Low percent output for loop 2. Usually set to 0.
LDL2 0000	Load line display for loop 2. Not used in this application
CV 2 CV 2	Selects the measured oxygen level as the control parameter for Loop 2
CM 1 D TP	Control mode for Loop 2 is selected to be Direct, Time Proportioning. This mode uses Control Contract 2 to regulate the process oxygen.
uSEV NO	Set to not use any internal events for control. This selection determines if event outputs 2 and 3 would be used for control based on the output contact selection. This selection is set to NO by the Lorox application.

Marathon Sensors Inc.

INPUT Setup Page	Description
MENU INP	Input setup menu heading.
IN A TCK	Input type selection for Input A. This selection is automatically set by the Lorox application and is used to measure the probe temperature.
CJCA YES	Cold junction for Input A. Automatically set to Yes because a thermocouple is connected to the Dualpro
IAOF 0000	Input A offset. Only used if PROG was selected for input type.
IASP 0100	Input A span adjustment. Only used if PROG was selected for input type.
IADP 0	Input A decimal point location. Selected to show a full four digit temperature display with no fractional degrees.
USRA NO	User scaling selected. Not used in this application.
UAOF 0000	User scaling offset. Not used in this application.
UASP 1.000	User scaling span. Not used in this application.
IN B PROG	Input type selection for Input B. This selection is automatically set by the Lorox application and is used to measure the probe millivolts. This setting assumes the input is a linear value with an input range of 0 – 2000 mV.
CJCB NO	Cold junction for Input B. Automatically set to NO.
IBOF 0000	Input B offset. Calculated by the Lorox program to offset any millivolt level measured during the zero calibration sequence. The default value is 0.
IBSP 01.00	Input B span adjustment. Calculated by the Lorox program to adjust the signal slope at full scale. This value is calculated during the span calibration sequence. The default value is 1.00.
IBDP 0	Input B decimal point location. Selected to show a full four digit millivolt display with no fractional millivolts.
USRB NO	User scaling selected. Not used in this application.
UBOF 0000	User scaling offset. Not used in this application.
UBSP 1.000	User scaling span. Not used in this application.
IN C OFF	Input type selection for Input C. This selection is automatically set by the Lorox application.
CJCC NO	Cold junction for Input C.
ICOF 0000	Input C offset. Only used if PROG was selected for input type.
ICSP	Input C span adjustment. Only used if PROG was selected for input

Marathon Sensors Inc.

01.00	type.
ICDP 0	Input C decimal point location. Selected to show a full four digit temperature display with no fractions degrees.
UCRA NO	User scaling selected. Not used in this application.
UCOF 0000	User scaling offset. Not used in this application.
UCSP 1.000	User scaling span. Not used in this application.
FAC 1 through 3	Factor setting for pulse input on inputs A, B, or C. Not used in this application.
10P1 through 10P3	Exponent power setting for pulse inputs on A, B, or C. Not used in this application.
DPP1 through DPP3	Display decimal point setting for inputs A, B, or C when used with a pulse input. Not used in this application.
UN 1 through UN 3	Time or frequency unit selection for inputs A, B, or C. Not used in this application.
TC °C	Selects either F (Fahrenheit) or C (Celsius). Celsius is used in the Lorox application.

Analog Outputs Setup Page	Description
MENU AOUT	Analog Outputs setup menu heading
AO 1 CV 0	Analog channel 1 is selected to re-transmit the oxygen process in this example. Other selections can be made such as IN A (temperature), or IN B (probe millivolts)
AO1O 00.00	Analog channel 1 offset scales the 4.0 mA output level to the minimum value of the process selected in AO 1. The absolute process minimum does not have to be used. Sections of the process response can be used to improve output resolution.
AO1R 20.95	Analog channel 2 range scales the 20 mA output level to the maximum value of the process selected in AO 1. The absolute process maximum does not have to be used. Sections of the process response can be used to improve output resolution.
AO 2 IN A	Analog channel 2 is selected to re-transmit the probe heater temperature in this example. Other selections can be made.
AO2O 0000	Analog channel 2 offset scales the 4.0 mA output level to the minimum value of the process selected in AO 2. The absolute process minimum does not have to be used. Sections of the process response can be used to improve output resolution.
AO2R 1000	Analog channel 2 range scales the 20 mA output level to the maximum value of the process selected in AO 2. The absolute process maximum does not have to be used. Sections of the process response can be used to improve output resolution.

Marathon Sensors Inc.

Calculation Setup Page	Description
MENU CALC	Calculation setup menu heading
PF 1 150.0	Process factor 1 for carbon control. The default for this number is 150. Not used in the Lorox application
PF 2 150.0	Process factor 2 for dew point control. The default for this number is 150. Not used in the Lorox application
DP C STD	Std/PIC standard or piccolo probe based. Use the piccolo option only if non-air reference gas is used. Not used in the Lorox application
DP °F	Choice of dewpoint calculations done in Centigrade or Fahrenheit. Not used in the Lorox application.
O2Of 0000	This offset is added to the probe millivolt reading (input B) before it is used in calculating percent Carbon or dewpoint. Not used in the Lorox application.
FILC NO	If no, then the display and datalogged % carbon values are instantaneous. If yes then the display and datalogged % carbon values are an average over the specified filter time. The instantaneous values are always used for control. Not used in the Lorox application.
CFTI 000.1	A sliding window average of the % values is computed over the specified time. Not used in the Lorox application.
FILD NO	If no, then the display and datalogged dewpoint values are instantaneous. If yes then the display and datalogged dewpoint values are an average over the specified filter time. The instantaneous values are always used for control. Not used in the Lorox application.
DFTI 000.1	A sliding window average of the dewpoint values is computed over the specified time. Not used in the Lorox application.
O2EX 2	Oxygen exponent (0 to 31). When the oxygen calculation is selected this setup determines the units. A value of 2 represents 10 ² therefore the units are percent. A value of 6 would have units of ppm (parts per million). This parameter is automatically set by the Lorox application.
O2DP 2	Oxygen Decimal Place. When the Oxygen calculation is selected this value determines the resolution to which the calculated value is displayed. For example by changing the decimal place the %O in the atmosphere could be displayed as 21, 20.9, or 20.95. This parameter is automatically set by the Lorox application.
MET 0	This value selects the metal contents for the redox calculation. Not used in the Lorox application.

Marathon Sensors Inc.

Alarms Setup Page	Description
MENU ALRM	Alarms setup menu heading
AL1M R.BN2	Alarm 1 Mode, shows BN2 for band detection above and below the loop 2 set point. If the band set by the alarm value is 0.50% oxygen and the SETPOINT is 2.0% then alarm will trigger at 2.5% and 1.5% . The "R." indicates that the contact closure is reversed, where it opens when the alarm occurs.
AL1V 00.50	Alarm 1 Value, sets the alarm trip point. Alarm value is consistent with the process variable selected in AL1M.
A1TN 0000	Alarm 1 Turn On Delay, 0000 to 0250 seconds. Sets a delay period between alarm condition and alarm activation.
A1TF 0000	Alarm 1 Turn Off Delay, 0000 to 0250 seconds. Sets a delay period between alarm condition and alarm deactivation.
AL2M R.PRQ	Alarm 2 Mode, shows PROG for program alarm. This alarm will react to any program alarms generated by the Lorox program. These alarms will also be displayed as PAL XXX, where XXX is the PAL alarm code. See the section on System Alarms for more information about PAL alarms.
AL2V 1000	Alarm 2 Value, sets the alarm trip point. Alarm value is consistent with the process variable selected in AL2M. Since PROG is selected any process number entered here will have no effect.
A2TN 0000	Alarm 2 Turn On Delay, 0000 to 0250 seconds. Sets a delay period between alarm condition and alarm activation.
A2TF 0000	Alarm 2 Turn Off Delay, 0000 to 0250 seconds. Sets a delay period between alarm condition and alarm deactivation.

Program Setup Page	Description
MENU PROG	Program setup menu heading
PRGP 0000	Program Partition, if 0000 the feature is deactivated. If 1 to 200, the number set will represent the partition between background and foreground programs. Programs whose numbers are above the partition may only be run in the foreground and programs whose numbers are below the partition may only be run in the background. This setting applies if the FPRG parameter is set to VER4.
FPRG VER3.5*	Foreground Program Type, If set to VER4 then the foreground programmer uses a standard LOGIC language program. (The same as the background program.) If set to V3.5* then the foreground program is a RECIPE type language program.
PAHT 0	Program Alarm Hold Time, sets the "Hold Time" to latch a PAL (Program Alarm) for HOLD TIME Data-logging purposes. An alarm will be held in the internal alarm stack for the time specified, after which the oldest PAL will be cleared. The delay time set should be based on the scan time of the

Marathon Sensors Inc.

	data-logging system attached to the instrument. This setting will have no visual effect on front panel operations. Selections are 0, 10, 30, 60, 90, 120, 180 seconds.
TCO 0000	Thermocouple Offset. This parameter is related to Alarm 85 function available in V3.5 recipes. It sets the allowed temperature deviation between the probe thermocouple (input A) and the temperature control thermocouple (input C) when Alarm 85 is activated in a recipe.
AUTO NO	Recipe Program Auto Continue. If YES, allows for the automatic continuation of a recipe that was running when the instrument lost power for a period of more than 10 seconds. If NO, does not continue the recipe when power is reapplied. Note: Recipes will auto-start regardless of selection if power loss is less than 10 seconds.
APS YES	Background Program Auto Continue. Yes forces the background program to restart at program 1, step 1, whether it was running or not, when power is reapplied after a power loss. No does not force the background program to start when power is reapplied. This parameter is automatically set by the Lorox program the first time it is run.
ABS YES	Auto Background Program Start. If YES, the background (logic) program is started at program 1 step 1 even if the background program has been manually stopped or stopped for more then 5 seconds. ABS is automatically set to YES by the Lorox program since the background program is necessary to control this application.
LOCK 3	Lock Level, Requires a password entry for access. LOCK LEVEL DEGREE OF ACCESS 0 NO ACCESS (lowest level) 1 LIMITED ACCESS 2 SOME RESTRAINTS / RECIPE EDIT 3 FULL ACCESS (highest level)
H OP NORM	H Opcode Redirection, selects whether or not to activate the temperature redirection option. If ' NORM ' is selected it is assumed the temperature set point command in a recipe is directed to an internal loop of the Dualpro. If ' DIR ' is selected, the set point command is directed to an attached temperature slave instrument.
H CH 0	H Opcode Channel, selects the channel number of the slave instrument where the temperature setpoint is to be directed. 0 refers to the master Dualpro, numbers 1 through 15 refer to other attached Dualpro controllers.
H SL H1	H Opcode Slave Channel, selects the slave temperature controller that is attached to the selected H CH instrument. This allows a temperature set point to be passed through attached Dualpros and directed to a slave instrument of the specified Dualpro.

Communication Setup Page	Description
MENU COM	Communications setup menu heading
HOST	Host Port Parity, selections include HE = Half Duplex Even Parity

Marathon Sensors Inc.

HE	HN = Half Duplex No Parity, FE = Full Duplex Even Parity, FN = Full Duplex No Parity
HOST 19.2K	Host Port Baud Rate, selections include 1200, 2400, 4800, 9600, 19.2K, 38.4K, 76.8K.
HPRO MMI	Host Protocol, selections include, MMI = Marathon Proprietary Protocol, and MOD = MODBUS RTU Protocol
HMAD 0000	Host Modbus Address, address used if Modbus protocol is selected. If set to 0 then the dipswitch SW2 address setting is used.
V3AD 0	Version 3 Address, Setting 0 uses the SW2 dipswitch settings. Settings 1 through 15 respond to the numbered address. The version 3 address is used when a Dualpro is replacing a Version 3 Carbpro connected to a Process Master 5.x system. The Dualpro will evaluate a Version 3 Carbpro at the specified address but will also respond to Version 4 requests at the dipswitch address.
V3CV YES	Version 3 Program Conversion, YES translates the version 3 recipe programs in version 3 mode. NO passes the program through without conversion utilities. If a Dualpro replaces a version 3 instrument, the programs must be converted.
SPAD 0	Secondary Port Address, if set to 0 then the secondary port is inactive. This feature sets a second address at which the instrument will respond on the host port. The secondary port table parameter selects which parameter table will be set for block reads.
STBL 0	Secondary Port Table, sets table 0 to 31 to be used with the secondary port address.
AUXM OFF	Aux Port Mode, selects the auxiliary ports mode of operation; BRoaDcast, TEMperature buss, network MASTer, OFF, LISTen, UDC, or TOKen.
AUX HE	Aux Parity, selects the auxiliary port parity setting; HE = Half Duplex Even Parity, HN = Half Duplex No Parity, FE = Full Duplex Even Parity, FN = Full Duplex No Parity
AUX 19.2K	Aux Baud Rate, selections include 1200, 2400, 4800, 9600, 19.2K, 38.4K, 76.8K.
TADR 0	Token Ring Address, determines which token address the instrument uses when the Aux port is in token mode. When set to 0, the instrument responds to the dipswitch settings. When set to 1 through 15, the instrument responds to that address. This allows address assignments independent of the HOST port address.
AMAD 0000	Aux Modbus Address, if the Aux Port Mode is set to 'MOD,' this parameter determines the Modbus slave address to which the instrument will respond. If this value is 0 then the HOST dipswitch address will be used.
MBTP 0	Master Bus Time Out Partition, used only when the Aux port is in Master or Token mode. Selects the channel number at or above which the MBTO value is used instead of the normal time out value. This feature is disabled if set to 0. This feature is used when a slower device (such as a PLC) is connected to the MSI network

Marathon Sensors Inc.

	and emulating a MSI instrument.
MBTO 00.12	Master Bus Time Out Value, when the MBTP is non-zero, this value is used as the bus time out value when attempting to communicate with channels equal to MBTP and above.
MBWP 0	Master Bus Write Partition, used to define unused slave channels that can be used by the programmer for additional memory space. Indirect writes to channel numbers equal to or above the MBTP (if active) will be stored into memory allocated for these channels. These values can later be read by with indirect reads.
RBIT NO	Local Mode Slave Indicator, selects whether the local mode indicator of the slave temperature controller should use BIT 12 of the actual setpoint. Use YES for compatibility with old applications. Select NO for most new ones.
BASP BAS	Basic Port Mode, when set to BAS, Basic programs may be run and the basic port is used only for BASIC communications. When set to TEMP, Basic programs may not be run and the port is then used as a temp buss at 4800 BAUD. This is allowed only if the Aux port is not set to UDC or TEMP. TEMP allows the instrument to operate a Master Network on the Aux bus and a temp instrument network on the Basic bus. This setting should be set to BAS for the Lorox application.

Events Setup Page	Description
MENU EVTS	Events setup menu heading
EP I 4	Internal Event Partition, where 0 configures all the internal events as inputs and 4 sets them all to outputs. A 1 will represent 1 output and 3 inputs, and so on until when at 4 all outputs are set. The Lorox program automatically sets this parameter to 4.
#XEV 0	Number of External Event Boards, representing the number of digital, event boards attached to the Dualpro. No external events boards are used in the Lorox application.
EVBD 4800	External Events Baud Rate, can be set to 1200 (for 1200 BAUD) or 4800 (for 4800 BAUD). Not used in the Lorox application.
DUAL NO	Dual Bus Mode, YES or NO. If yes and the Basic port is not temp and the Aux port is not temp or UDC, the events buss is used for both events boards and temperature controllers. Not used in the Lorox application.
UDCP 0	UDC Partition, 0 to 8. Sets the number of UDC instruments that are installed on the Events port in dual buss mode. The UDC's use the high address numbers in the range 1-8. Not used in the Lorox application.
EPX1 0	External Event Brd 1 Partition, 0-15. 0 implies all inputs, and 15 implies 15 outputs and 1 input for the first digital events board. 5 implies 5 outputs and 11 inputs; and so on. Not used in the Lorox application.
EPX2 0	External Event Brd 2, 0-15. 0 implies all inputs, and 15 implies 15 outputs and 1 input for the second digital events board. 5 implies 5 outputs and

Marathon Sensors Inc.

	11 inputs; and so on. Partition Not used in the Lorox application.
EPX3 0	External Event Board 3 Partition, 0-15. 0 implies all inputs, and 15 implies 15 outputs and 1 input for the third digital events board. 5 implies 5 outputs and 11 inputs; and so on. Not used in the Lorox application.
EPX4 0	External Event Board 4 Partition, 0-15. 0 implies all inputs, and 15 implies 15 outputs and 1 input for the forth digital events board. 5 implies 5 outputs and 11 inputs; and so on. Not used in the Lorox application.
EMAP NO	Events Mapping, YES / NO. Yes activates logical events mapping. Refer to the programmer's manual for complete information on logical event mapping. The Lorox program automatically sets this parameter to NO.

Remote Events Setup Page	Description
MENU AEVT	Analog (external) events setup menu heading
XAAO	External Analog Address Offset, normally set to 0 and the Analog OPTOMUX board connected to the instrument has an address of FC hex. When 1, then the Analog OPTOMUX used by the instrument is at address FD hex. Likewise, when 2, the address is FE hex, and 3 produces an address of FF hex. This is used when more than one Analog OPTOMUX is connected to the instrument. Not used in the Lorox application.
N/A	All other parameters are not applicable to the Lorox program.

Probe Setup Page	Description
MENU Prob	Probe Maintenance setup menu heading
PT I 0000	Probe Test Interval, Not used in the Lorox application.
PIMP 020.0	Maximum Probe Impedance, Not used in the Lorox application.
Prt 0030	Probe Test Recover Time, Not used in the Lorox application.
BO T 0030	Probe Burnoff Time, Not used in the Lorox application.
Bort 0030	Probe Burnoff Recover Time, Not used in the Lorox application.
F De 0030	Final Delay, Not used in the Lorox application.
TA1 0000	Verification Time 1 Average, Not used in the Lorox application.
TA2 0000	Verification Time 2 Average, Not used in the Lorox application.
TD1	Time 1 Delay, Not used in the Lorox application.

Marathon Sensors Inc.

0000	
TD2 0000	Time 2 Delay, Not used in the Lorox application.
VGAS 000.0	Verification Gas Value, Not used in the Lorox application.
VTOL 000.0	Verification Test Tolerance, Not used in the Lorox application.
Inhb YES	Inhibit Test? The Lorox program automatically sets this parameter to YES.

Process Factor Adjust Setup Page	Description
MENU PF-A	Process Factor Adjust setup menu heading
PFIR NONE	Process Factor IR Adjustment mode, selects the type of interaction possible if an IR 3 gas measurement system. NONE turns of IR functions. ICCO accepts a linear input on IN C that is proportional to the CO level. IRCO accepts the CO level from the IR system using the Token bus. IRMO monitors the gases measured by an IR system via the Token bus. IRPF provides full control of the process factor using the carbon calculation from the IR system. Not used in the Lorox application. Leave this parameter set to NONE for the Lorox application.
MVLo 0000	Probe millivolt Minimum Limit is the minimum millivolt level of the furnace probe that must be achieved to allow IR sampling. Not used in the Lorox application.
MVHi 2000	Probe millivolt Maximum Limit is the maximum millivolt level of the furnace probe that must be achieved to allow IR sampling. Not used in the Lorox application.
TCLo 0800	Temperature Minimum Limit, Not used in the Lorox application.
TCHi 1800	Temperature Maximum Limit, Not used in the Lorox application.
COLo 00.00	CO Minimum Limit sets the minimum allowed CO level measured by IR system with a range of 0.0%CO to 30.0%CO. This level also applies for the CO Compensation options. Not used in the Lorox application.
COHi 25.00	CO Maximum Limit sets the maximum allowed CO level measured by IR system with a range of 0.0%CO to 30.0%CO. This level also applies for the CO Compensation options. Not used in the Lorox application.
CO2L 0.000	CO2 Minimum Limit sets the minimum allowed CO ₂ level measured by IR system with a range of 0.0%CO ₂ to 5.0%CO ₂ . Not used in the Lorox application.
CO2H	CO2 Maximum Limit sets the maximum allowed CO ₂ level

Marathon Sensors Inc.

0.800	measured by IR system with a range of 0.0%CO ₂ to 5.0%CO ₂ . Not used in the Lorox application.
CH4L 00.00	Methane Minimum Limit sets the minimum allowed CH ₄ level measured by IR system with a range of 0.0%CH ₄ to 20.0%CH ₄ . Not used in the Lorox application.
CH4H 05.00	Methane Maximum Limit sets the maximum allowed CH ₄ level measured by IR system with a range of 0.0% CH ₄ to 20.0%CH ₄ . Not used in the Lorox application.
PFLo 0050	Process Factor Minimum Limit sets the maximum allowed CH ₄ level measured by IR system with a range of 0.0% CH ₄ to 20.0%CH ₄ . Not used in the Lorox application.
PFHi 0480	Process Factor Maximum Limit sets the maximum limit of the Process Factor value with a range of 000 to 999. This parameter also applies for the CO Compensation options. Not used in the Lorox application.
MXAd 0005	Maximum PF adjustment sets maximum allowable Process Factor adjustment per IR sample that the instrument can make with a range of 000 to 100. This parameter also applies for the CO Compensation options. Not used in the Lorox application.
TCSR IN A	Thermocouple Source Where IN A, IN C, or IR can be selected. If input A or C are selected these temperature values are transmitted to the IR system and used as the default temperature values for that point at the IR system. If IR is selected the manually entered default temperature at the IR system for that point is use. Not used in the Lorox application.

Calibration Procedures

Lorox Probe Calibration

The Lorox controller can perform an automatic calibration on the Lorox probe by change N5 to 1 or by setting N6 to the required time at which a calibration should be done. It is also possible to perform a manual calibration by manually turning on/off the zero and span gas events.

Before the controller can be used to calibrate in automatic mode it is necessary to know what the required delay times for zero process, the span process, and the amount of time required to return to the normal process level. The calibration program uses the same time for the zero and span delays (seconds), so the maximum time of either process will be used. The final delay time is the time (seconds) required for the probe to start to correctly register the process gas following the calibration cycle.

Manual Lorox Probe Calibration

Warning

When the Lorox probe is calibrated manually, the analog output channels are **not** frozen. The analog output 4-20mA loops will react to the zero and span gases as if they were changes in the process gas. Automatic calibration through either N5 or N6 will freeze the analog output channels.

Warning

Insure that any system interlocks connected through the Dualpro will not be tripped during manual calibration of the Lorox probe or during calibration of the Dualpro analog inputs or outputs.

Three display menus will be used during this calibration process; the EVENT and DATA displays under the [Page Disp] key, and the INPUT menu under the [Setup] key. Refer to the section on the [Page Disp] menus for more information. The procedures for viewing and setting the required parameters follows the manual calibration procedure.

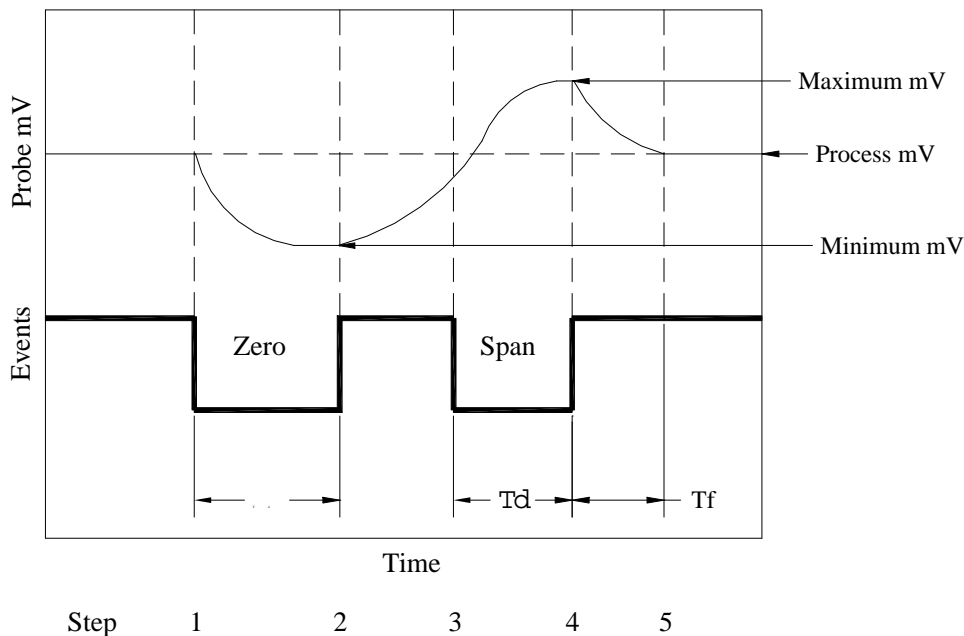

Figure 9 Calibration Sequence

Step 1

- Note average process value (mV)
- Turn on the zero event (EV0) and note start time
- Check and adjust zero cal gas flow for 5 SCFH minimum
- Verify that that the probe millivolt level drops

Step 2

- Note elapsed time for a stable minimum reading, this is the Zero Time Delay
- Note the minimum millivolt level, this is the Zero Offset Value
- Turn off the zero event (EV0)

Step 3

- Turn on the span event (EV1) and note time
- Verify a span gas flow of 5 SCFH minimum
- Verify that the probe millivolt level increases

Step 4

- Note the elapsed time for a stable maximum reading, this is the Span Time Delay
- Note the maximum millivolt level, this is the Span Value
- Turn off the span event (EV1)
- Note start time

Step 5

- Note elapsed time when the millivolt level returns to the normal process range, this is the Final Delay Time

Turning on the Events

The events on the Dualpro can be turned on by:

- Pressing the [Page Disp] key
- Press the [RIGHT] key until EVNT is displayed
- Press the [DOWN] key once to display SP 0
- Press the [Shift] + [Setpt] keys at the same time.
- Select 0oF (if not displayed) by pressing the [UP] or [DOWN] keys
- Turn EV0 on (of off) by pressing the [RIGHT] (or [LEFT]) keys
- Press [Page Disp] to exit

Event 1 operates the same way when it is selected using the same procedure. It is displayed as 1oF or 1on when selected.

Viewing the Probe Data

A number of process values are displayed in the DATA menu screen. Press the following keys to view this information.

Press the [Page Disp] key

Press the [RIGHT] key until DATA is displayed

Press the [DOWN] key to view system data.

CJ	Instrument cold junction temperature
IN A	Probe temperature (C or F)
IN B	Probe millivolts
IN C	Not used
CV0	% Oxygen
CV1	Not used
CV2	% Oxygen
CV3	Calculated span millivolts based on probe temp and value in N1

Entering the Offset and Span Correction Values

The offset and span correction values from the work sheet in Appendix D are entered using the following steps;

- Press the [Setup] key
- Press the [RIGHT] key until the MENU INP is displayed
- Press the [Enter] key until IN B is displayed, verify PROG is set
- Press the [Enter] key to display IBOF
- Enter the Offset number as a whole number integer, i.e. if the actual millivolt reading was 16.67 millivolts, enter 17.
- Press the [Enter] key to display IBSP
- Enter the calculated span value from the worksheet

Marathon Sensors Inc.

You can initiate another span calibration cycle and verify that the oxygen reading is the same as the span gas value. Otherwise the probe has been calibrated to the span gas.

Automatic Lorox Probe Calibration

There are a number of parameters that must be set to perform an automatic calibration. These parameters are set by entering the [Setpt] menu. Press the [Setpt] key and enter the following values that were obtained from the worksheet in Appendix D.

Table 2 System Set Points and Registers

Process Display	Setpt Display	Action Required
SP1	Loop 1 set point value	Press [Enter] for next
SP 2	Loop 2 set point value	Press [Enter] for next
RN	Reference Number	Press [Enter] for next
N1	Span Gas value i.e. 200 = 2.00% oxygen	Set value and press [Enter] for next
N2	Calibration Sample Delay Time (seconds)	Set time for the zero and span delay time. Press [Enter] for next
N3	Not used	Press [Enter] for next
N4	Calibration Final Delay Timer (seconds)	Set time required for the process to return to normal. Press [Enter] for next
N5	Manual Cal request, 0 = no request, 1 = manual request	Press [Enter] for next
N6	Calibration Start Time i.e. 0800 = 8:00am or 1600 = 4:00pm. 0000 turns off auto-cal function	Set time for automatic cal to start. Press [Setpt] to exit. (Check Real Time Clock to make sure time is correct)

When a Calibration Start Time is reached or if N5 is changed to 1, the automatic calibration function is activated. A manual request (N5) generates an immediate calibration. The Start Time in N6 is compared to the instrument's Real Time Clock. A calibration cycle starts if the time entered in N6 equals the Real Time Clock. The following chart shows examples of time entries.

Table 3 Calibration Interval Setting

Desired Start Time	Number in N6	Comments
08:00 am	800	Enter 800 for 8:00
6:30 pm	1830	Enter 1830 for 6:30
12:00 pm	Not valid	0000 turns off auto-cal function. Use 2359 or 0001 for midnight.
12:00 am	1200	Enter 1200 for 12:00

Dualpro Calibration

Refer to the Dualpro Operations Manual chapter on calibration for information about calibrating the Dualpro instrument analog inputs and outputs.

The Dualpro that is used in the Lorox has a standard T/C, MV, T/C configuration. Refer to the Dualpro Operations Manual Calibration sections for the thermocouple and probe millivolt inputs.

Warning

During Dualpro calibration, the analog output channels (4-20mA) will slew from zero (4mA) to span (20mA) levels during the zero and span settings for any of the three input channels.

Maintenance

Lorox Probe

The probe is a self-heated device that is mounted into the process flue with a flange interface. The probe is internally heated to an operating temperature of 750°C with the application 120VAC power. It is necessary to secure this power source before any service is attempted. It is important to remove power from the probe and allow the probe to cool before any component replacement is attempted.

Power can be removed from the circuit by pulling fuse 128FU.

Refer to the Lorox Sensor Manual for details on how to disassemble and reassemble the sensor.

Dualpro

The Dualpro is easily serviced in the field with the ability to replace function specific cards located behind the front panel. To access these circuit boards, unscrew the panel screw at the bottom of the keyboard.

Remove the keyboard panel and turn off the toggle switch on the right hand board. Remove the keyboard panel by unplugging the ribbon cable connector.

The circuit boards are laid out from right to left as:

- Triac board
- Interface board (display / keyboard plug)
- CPU board
- Communication board
- Analog Output board
- Analog Input board

Warning

Do not remove the Triac board unless all power is removed from the rear panel of the instrument. See panel jumper 119JP. All other boards can be removed when the power toggle switch on the Triac board is turned off.

Contact Marathon Sensor Inc. for any questions regarding the operation of this product. Refer to the Dualpro Operations Manual for more details about each circuit board and how to configure the instrument.

Appendix A – mV to Percent Oxygen Chart

Probe MV	Probe Temp deg C	Process %O2	Probe MV	Probe Temp deg C	Process %O2
0	750	20.95%	41	750	3.25%
1	750	20.02%	42	750	3.10%
2	750	19.13%	43	750	2.97%
3	750	18.28%	44	750	2.83%
4	750	17.47%	45	750	2.71%
5	750	16.69%	46	750	2.59%
6	750	15.95%	47	750	2.47%
7	750	15.24%	48	750	2.36%
8	750	14.56%	49	750	2.26%
9	750	13.92%	50	750	2.16%
10	750	13.30%	51	750	2.06%
11	750	12.71%	52	750	1.97%
12	750	12.14%	53	750	1.88%
13	750	11.60%	54	750	1.80%
14	750	11.09%	55	750	1.72%
15	750	10.59%	56	750	1.64%
16	750	10.12%	57	750	1.57%
17	750	9.67%	58	750	1.50%
18	750	9.24%	59	750	1.43%
19	750	8.83%	60	750	1.37%
20	750	8.44%	61	750	1.31%
21	750	8.06%	62	750	1.25%
22	750	7.71%	63	750	1.20%
23	750	7.36%	64	750	1.14%
24	750	7.04%	65	750	1.09%
25	750	6.72%	66	750	1.04%
26	750	6.43%	67	750	1.00%
27	750	6.14%	68	750	0.95%
28	750	5.87%	69	750	0.91%
29	750	5.61%	70	750	0.87%
30	750	5.36%	71	750	0.83%
31	750	5.12%	72	750	0.79%
32	750	4.89%	73	750	0.76%
33	750	4.67%	74	750	0.72%
34	750	4.47%	75	750	0.69%
35	750	4.27%	76	750	0.66%
36	750	4.08%	77	750	0.63%
37	750	3.90%	78	750	0.60%
38	750	3.72%	79	750	0.58%
39	750	3.56%	80	750	0.55%
40	750	3.40%	81	750	0.53%

How Do I Know if the Background Program is Running?

The Background program is running if the LED next to B Prog on the Dualpro front panel is lit. If this LED is not lit;

- Press the [Prog/Auto/Man] key twice.
- Press the [Enter] key once to display BPRG in the top display.
- Press the [DOWN] arrow key to change the lower display to RUN.
- Press [Enter]
- Use the arrow keys to change the number that is displayed to 0001.
- Press [Enter] again. The display will change to STEP.
- Use the arrow keys to change the number to 0001
- Press [Enter].
- The BPROG LED should now be lit.
- Press [Prog/Auto/Man] to exit

Can I change the calibration timers during a calibration?

All the instrument's timers can be accessed through the [Page Disp] TMRS (Timers) menu under the [Page Disp].

There are sixteen timers available in the Dualpro. The following timers are used in this application.

Table 4 Instrument Timer Definitions

Timer Name	Timer Function
T4	CAL SAMPLE DELAY TIMER (second down counter)
T5	T5 Not used
T6	CAL FINAL DELAY TIMER (second down counter)
T7	BASIC WATCHDOG TIMER, SET BY BASIC PROGRAM (second down counter)
TD	HEATER TIMER, TIME LIMIT FOR LOROX HEATER TO COME TO TEMP (minute down counter)

To change any timer, do the following;

- Press the DISP PAGE key
- Press the [RIGHT] key until TMRS is displayed
- Press the [Enter] key until TMR X is displayed, where X is the timer number
- Press the [Shift] + [Setpt] key at the same time
- Use the arrow keys to change the time to desired number
- Press the [Page Disp] key to exit

How do I set the REAL TIME CLOCK?

Press [Page Disp]

Select the VERSION page by pressing the [right] or [left] arrow keys.

Press the [down] key to display the date.

Press and hold [Shift] press [Setpt] with it to get a display that reads:

Marathon Sensors Inc.

MODE XXAB	This allows the clock flexibility in keeping dates accurate. The formula for mode is based on the "A" place being the number of years since the last leap year. The one's place is used for a numeric value for the day of the week. The "A's" values are only 0 to 3; the "B's" values are Sunday = 1 through Saturday = 7.
YEAR XXXX	Year can be from 1980 to 2079
MNTH XXXX	The month can be set to 0001 through 0012
DAY XXXX	Day is set as date value 0001 through 0031
HOURL XXXX	The hour is set in military time 0000 (midnight) to 23(11 P.M.)
MIN XXXX	Minutes are set from 0 to 59. If greater accuracy is needed, set the DUALPRO to the next minute and press the [Enter] key when your external time reference seconds are equal to zero.

Appendix C – Dualpro Setup

DUALPRO SETUP PARAMETERS

Firmware Version 130 or higher

DIP Switch Settings

SW1: ON – 2
OFF – ALL OTHERS
SW2: 1 2 3 4 N/A

CONTROL MENU		Default	New Setting
Parameters	Description		
PB 1	Proportion Band Loop 1	20	
RES 1	Reset Loop 1	0.20	
RAT 1	Rate Loop 1	0.00	
CYC 1	Cycle Time Loop 1	30	
HPO1	High output Loop 1	100	
LPO1	Low output Loop 1	0	
LDL1	Load line Loop 1	0	***
CV 1	Control Variable Loop 1	IN A	IN A
CM 1	Control Mode Loop 1	D TP	D TP
PB 2	Proportion Band Loop 2	20	
RES 2	Reset Loop 2	0.20	
RAT 2	Rate Loop 2	0.00	
CYC 2	Cycle Time Loop 2	30	
HPO 2	High output Loop 2	100	
LPO 2	Low output Loop 2	0	
LDL 2	Load line Loop 2	0	***
CV 2	Control Variable Loop 2	CV 2	CV 2
CM 2	Control Mode Loop 2	D TP	D TP
uSEV	Use Events for Control?	NO	NO

- GRAY BLOCK INDICATES PARAMETERS AUTOMATICALLY SET BY THE LOROX APPLICATION PROGRAM
- *** INDICATES NO APPLICATION TO LOROX PROGRAM

Marathon Sensors Inc.

INPUT MENU		Default	New Setting
Parameters	Description		
IN A	Input A Input Selection	TC K	TC K
CJCA	Input A Cold Junction compensation?	YES	YES
IAOF	Input A Offset	0000	***
IASP	Input A Span	01.00	***
IADP	Input A Decimal Point	0	***
USRA	Input A User Offset?	NO	NO
UAOF	Input A User Offset	0000	***
UASP	Input A User Span	1.000	***
IN B	Input B Input Selection	PROG	PROG
CJCB	Input B Cold Junction compensation?	NO	NO
IBOF	Input B Offset	0000	
IBSP	Input B Span	1.000	
IBDP	Input B Decimal Point	0	
USRB	Input B User Offset?	NO	NO
UBOF	Input B User Offset	0000	***
UBSP	Input B User Span	1.000	***
IN C	Input C Input Selection	OFF	OFF
CJCC	Input C Cold Junction compensation?	NO	NO
ICOF	Input C Offset	0000	***
ICSP	Input C Span	1.000	***
ICDP	Input C Decimal Point	0	***
USRC	Input C User Offset?	NO	***
UCOF	Input C User Offset	0000	***
UCSP	Input C User Span	1.000	***
FAC 1	Input A Pulse Factor	0.200	***
10P 1	Input A Pulse Power of 10	-3	***
DPP 1	Input A Pulse Decimal Place	XXXX	***
UN 1	Input A Pulse Units	1/TI	***
FAC 2	Input B Pulse Factor	0.200	***
10P 2	Input B Pulse Power of 10	-3	***
DPP 2	Input B Pulse Decimal Place	XXXX	***
UN 2	Input B Pulse Units	1/TI	***
FAC3	Input C Pulse Factor	0.200	***
10P 3	Input C Pulse Power of 10	-3	***
DPP 3	Input C Pulse Decimal Place	XXXX	***
UN 3	Input C Pulse Units	1/TI	***
TC	F or C?	°C	

- GRAY BLOCK INDICATES PARAMETERS AUTOMATICALLY SET BY THE LOROX APPLICATION PROGRAM
- *** INDICATES NO APPLICATION TO LOROX PROGRAM

Marathon Sensors Inc.

ANALOG OUTPUT MENU		Default	New Setting
Parameters	Description		
AO 1	Analog 1 Function	CV 0	
AO1O	Analog 1 Offset	00.00	
AO1R	Analog 1 Range	25.00	
AO 2	Analog 2 Function	IN A	
AO2O	Analog 2 Offset	0000	
AO2R	Analog 2 Range	1000	

CALCULATIONS MENU		Default	New Setting
Parameters	Description		
PF 1	Process Factor of Carbon	0150	***
PF 2	Process Factor of Dewpoint	0150	***
DP C	Dewpoint Type	STD	***
DP	Dewpoint F of C?	°F	***
O2oF	Probe mV Offset	0000	***
FILC	Filter Carbon Display?	NO	***
CFTI	Carbon Filter Averaging Time	000.1	***
FILD	Filter Dewpoint Display?	NO	***
DFTI	Dewpoint Filter Averaging Time	000.1	***
O2EX	Oxygen Exponent	2	2
O2DP	Oxygen Decimal Point	2	2
MET	Redox Metal Number	0	***

ALARM MENU		Default	New Setting
Parameters	Description		
AL1M	Alarm 1 Mode	R.BN2	
AL1V	Alarm 1 Value	00.50	
A1TN	Alarm 1 Turn On Delay	0000	
A1TF	Alarm 1 Turn Off Delay	0000	
AL2M	Alarm 2 Mode	D.PRG	
AL2V	Alarm 2 Value	1000	
A2TN	Alarm 2 Turn On Delay	0000	
A2TF	Alarm 2 Turn Off Delay	0000	

- GRAY BLOCK INDICATES PARAMETERS AUTOMATICALLY SET BY THE LOROX APPLICATION PROGRAM
- *** INDICATES NO APPLICATION TO LOROX PROGRAM

Marathon Sensors Inc.

PROGRAM MENU		Default	New Setting
Parameters	Description		
PRGP	Program Partition	0000	0000
FPRG	Foreground Program Type	VER3.5*	VER3.5*
PAHT	Program Alarm Hold Time	0	0
TCO	Thermocouple Offset	0000	0000
AUTO	Recipe Program Auto Continue?	NO	NO
APS	Background Prog Auto Continue?	YES	YES
ABS	Auto Background Prog Start?	YES	YES
LOCK	Lock Level	3	
H OP	H Opcode Redirection	NORM	***
H CH	H Opcode Channel	0	***
H SL	H Opcode Slave Channel	H1	***

COMMUNICATIONS MENU		Default	New Setting
Parameters	Description		
HOST	Host Parity	HE	***
HOST	Host Baud Rate	19.2K	***
HPRO	Host Protocol	MMI	***
HMAD	Host Modbus Address	0000	***
V3AD	Version 3 Address	0	***
V3CV	Version 3 Program Conversions?	YES	***
SPAD	Secondary Port Address	0	***
STBL	Secondary Port Table	0	***
AUXM	Aux Port Mode	OFF	***
AUX	Aux Parity	HE	***
AUX	Aux Baud Rate	19.2K	***
TADR	Token Ring Address	0	***
AMAD	Aux Modbus Address	0000	***
MBTP	Master Bus Time Out Partition	0	***
MBTO	Master Bus Time Out Value	00.12	***
MBWP	Master Bus Write Partition	0	***
RBIT	Local Mode Slave Indicator	NO	***
BASP	Basic Port Mode	BAS	BAS

- GRAY BLOCK INDICATES PARAMETERS AUTOMATICALLY SET BY THE LOROX APPLICATION PROGRAM
- *** INDICATES NO APPLICATION TO LOROX PROGRAM

Marathon Sensors Inc.

DIGITAL EVENTS MENU		Default	New Setting
Parameters	Description		
EP I	Internal Event Partition	4	4
#XEV	# of External Event Boards	0	***
EVBD	Events Baud Rate	4800	***
DUAL	Dual Bus Mode?	NO	***
UDCP	UDC Partition	0	***
EPX1	External Event Brd 1 Partition	0	***
EPX2	External Event Brd 2 Partition	0	***
EPX3	External Event Brd 3 Partition	0	***
EPX4	External Event Brd 4 Partition	0	***
EMAP	Events Mapping?	NO	NO

ANALOG EVENTS MENU		Default	New Setting
Parameters	Description		
XAAO	External Analog Address Offset	0	***
N/A	All other parameters are not applicable	N/A	***

PROBE MENU		Default	New Setting
Parameters	Description		
PT I	Probe Test Interval	0000	***
PIMP	Maximum Probe Impedance	020.0	***
Prtt	Probe Test Recover Time	0030	***
BO T	Probe Burnoff Time	0030	***
Bort	Probe Burnoff Recover Time	0030	***
F dE	Final Delay	0030	***
TA1	Verification Time 1 Average	0000	***
TA2	Verification Time 2 Average	0000	***
TD1	Time 1 Delay	0000	***
TD2	Time 2 Delay	0000	***
VGAS	Verification Gas Value	000.0	***
VTOL	Verification Test Tolerance	000.0	***
Inhb	Inhibit Test?	YES	YES

- GRAY BLOCK INDICATES PARAMETERS AUTOMATICALLY SET BY THE LOROX APPLICATION PROGRAM
- *** INDICATES NO APPLICATION TO LOROX PROGRAM

Marathon Sensors Inc.

PF-IR ADJUST MENU		Default	New Setting
Parameters	Description		
PFIR	Process Factor IR Adjustment mode; NONE, ICCO, IRCO, IRMO, IRPF	NONE	NONE
MVLo	Probe millivolt Minimum Limit	0000	***
MVHi	Probe millivolt Maximum Limit	2000	***
TCLo	Temperature Minimum Limit	0800	***
TCHi	Temperature Maximum Limit	1800	***
COLo	CO Minimum Limit	00.00	***
COHi	CO Maximum Limit	25.00	***
CO2L	CO2 Minimum Limit	0.000	***
CO2H	CO2 Maximum Limit	0.800	***
CH4L	Methane Minimum Limit	00.00	***
CH4H	Methane Maximum Limit	05.00	***
PFLo	Process Factor Minimum Limit	0050	***
PFHi	Process Factor Maximum Limit	0480	***
MXAd	Maximum PF adjustment	0005	***
TCSR	Thermocouple Source	IN A	***

- GRAY BLOCK INDICATES PARAMETERS AUTOMATICALLY SET BY THE LOROX APPLICATION PROGRAM
- *** INDICATES NO APPLICATION TO LOROX PROGRAM

Marathon Sensors Inc.

Appendix D – Calibration Work Sheet

Average process value (DATA INPUT B) _____(mV)

Zero Offset Value (Eo) (DATA INPUT B) _____(mV)

Zero Time Delay _____(sec)

Span Value (Es) (DATA INPUT B) _____(mV)

Span Time Delay _____(sec)

Final Time Delay (N4) _____(sec)

IBSP span correction value
(*see below for calculation) _____

Greater number of Zero Delay or Span Delay (N2) _____(sec)

***Calculate equivalent span millivolt value**

Perform the following to calculate the required IBSP (Input B span in INPUT Menu). Look up the equivalent millivolt when the span gas is flowing as shown in Appendix A if the actual temperature is 750°C or calculate using equation;

$$Eq = 0.0215 * Tk * LN(20.95 / Span\%)$$

Where:

- Tk = Actual Temp (°C) + 273.15
- LN = Natural Log function
- Span% = Span gas oxygen % value
- Eq = Equivalent millivolt value

Calculate Input B span value correction

Use the following equation to calculate the input span value correction;

$$I_{bsp} = E_q / (E_s + E_o)$$

Where:

I_{bsp} = the IBSP span correction of input B

E_q = the equivalent millivolt from the previous equation

E_s = Span millivolt from work sheet

E_o = Offset millivolt from work sheet